



Our Manufacturing facility in Italy

INDEX

Technical characteristics	pag. 4-5
Efficiency	pag. 6
Protection	
Working conditions	
Rotomotive motors protection	pag. 7
Wiring diagrams	pag. 8
Technical data	pag. 9
Performance chart EFF2	pag. 10
Performance chart EFF2	pag. 11
Performance chart EFF2	pag. 12
Performance chart EFF2	pag. 13
Performance chart - IE2	pag. 14
Performance chart - IE3	pag. 15
Optional Accessories & features	pag. 16
Custom built motors/Smoke & heat exhaust ventilation motor	pag. 17
Dimensions Chart	pag. 18-19
Delphi ATDC, ATAC & AT24	pag. 20
Brake description	pag. 21
Brake operation	
Adjustment	
Switching (ATDC)	
Crane duty motors	pag. 22
Performance chart	pag. 23
Delphi Exd series	
Flame proof motors	pag. 24-25
Component list	pag. 26
ISO Certificate	
CE Marking	



A



B



C



D



TECHNICAL CHARACTERISTICS

Rotomotive asynchronous three phase Delphi series motors are built with dimensional conformance to Indian Standard IS:1231, IS: 2223 & International standard IEC 72-1.

The mounting positions as per IS : 2253 and IEC 34-7 are B3, B5, B14 and B35.

Rotomotive motors are totally enclosed, and fan cooled. Non-standard versions in TENV construction are also available on request.

The frame sizes upto 132 are made from light weight die cast aluminium alloy and from size 160 up to 355 the frame and end-covers are made from cast iron.

All motors are
multiple voltage
multi-frequency 50/60Hz,
F class insulation, (H class on request)
S1 continuous duty service,
IP55 protection, (IP66 on request)
1 or 2 efficiency class
IE2 or IE3 efficiency class (IEC 60034-30)
tropicalized winding

EFF 2

PATENTED

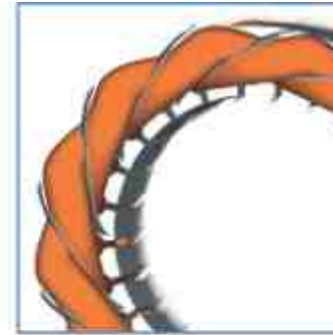

The windings are vacuum impregnated under pressure with F class insulating enamel to ensure high resistance to electrical, thermal and mechanical stresses.

The phases are further isolated by another layer of phase separator insulating film to protect the motors from the voltage spikes that usually occur when the motor is controlled by an inverter.



Rotomotive motors use shielded bearings with C3 clearance to ensure low noise and higher reliability. The rotor is dynamically balanced according to IS : 12075 as well as IEC 34-14 and ISO 9921/ ISO 8821 norms.



Securing the bearings into their seats with internal circlips prevents them from moving axially. From frame size 90, a steel insert is provided in the bearing seats on both the aluminium end-covers, so as to provide high resistance to the radial mechanical forces



Cable gland can be easily moved on both the sides of the terminal box, and other end can be sealed using screwed cap.



The terminal box can be rotated of 360° in steps of 90°



To protect against corrosion and rusting, Rotomotive motors are painted with RAL9006 silver colour upto 132 frame and from frame size 160 onwards, motors are painted with RAL 5007 blue colour.

From size 160 and up, due to the high torque, the motors are fixed with feet that are die-casted with the iron frame



Superior efficiency and performance is achieved through use of low loss **CRNO** magnetic laminations instead of the usual **Semi Processed/Decarb** material. **CRNO laminations** enable higher efficiency, lower heating, promote energy saving, age slower and reduce thermal stresses on insulation materials.

From frame size 56 to 132, Feet and the terminal box can be moved to the right or left



EFFICIENCY

Limited energy resource and high interest cost of addition of new generation capacity is leading to an increase in the cost of electrical energy in India. The Bureau of Indian standards, with an aim to promote energy conservation has specified efficiency levels for motors termed as 'Energy Efficient motors' in its standard **IS: 12615**. These are categorized as IE1, IE2 & IE3. Please see table on page 14 for comparison and details.

Rotomotive motors are designed and manufactured to meet all the requirements of the standard IS: 12615 as well as the European agreement issued by the European commission and CEMEP (European Committee of Manufacturers of Electrical Machines and Power Electronics). The prime benefits of using Energy Efficient motors are:

IMMEDIATE SAVING IN POWER COST:

Though actual savings may depend on type of use and duration, generally, EFF2 level motors reduce the power cost by about 20%. For instance, a 15 KW motor for an operation period of 6,000 hours per year can save about 2 MWhr or more, resulting in a **direct saving of about Rupees 8000 per year.**

HIGHER DURABILITY:

Higher efficiency motors heat less slowing down the aging of the insulating materials and thereby prolonging their reliability and life. Considering an average operation of 2500 hours/ year for motors up to 15KW and 4000 hours / year for motors rated higher than 15KW, the expected life is approximately 12 years.

ENVIRONMENT FRIENDLY:

Efficiency 2 motors guarantee great energy and cost savings, and consequently reduce the use of resources which generate CO₂ emissions. This eventually improves the quality of our environment.

HOW TO MAKE A MORE EFFICIENT MOTOR?:

High efficiency can be seen in many ways: like the relation between output power and input power or like a measure of the losses that occur when converting the electric power into mechanical energy. From another perspective, energy efficient motors consume less energy to produce the same torque at the shaft.

An energy efficient motor is the result of use of low loss materials, precise construction, lower frictional losses, dynamically balanced rotor, and lesser air-gap between rotor and stator. **The main design factors are based on the choice of the type of lamination and windings with a higher conductor diameter.** Among all materials that compose a motor, quality of laminations have the highest influence on performance.

SILICON MAGNETIC LAMINATIONS

Rotomotive motors are made with **CRNO** magnetic lamination sheets, rather than the usual **Semi Processed/Decarb** lamination sheets.

Apart from the choice of material, the thickness of laminations has a significant impact on performance.

In fact, thinner is the sheet higher is the performance.

The lamination sheets **Semi Processed/Decarb** can reach up to 1mm thickness.

CRNO magnetic lamination sheets have a 0.5mm maximum thickness

Material composition and thickness of magnetic laminations result in a very low Watts loss/kg.

Lower specific losses mean less magnetising current for the same Power and torque (thus lesser heating)

EURO NORM	Watts loss/Kg at 1T	Watts loss/Kg at 1.5T
106-84	1.70	4.00

data at 400V 50Hz

Instead, no standard prescribes a maximum watts loss factor for **Semi processed/Decarb** lamination sheets although it is considered to be generally double of **CRNO** lamination sheet. There is ofcourse a wide variation even in these values.

Amongst all the raw materials that are used in an asynchronous electric motor, laminations have the greatest contribution in determining the performance.

The main advantages of use of silicon steel laminations are:

- Higher Efficiency
- Better guarantees on the quality consistency, and assurance of achievement of efficiency tolerances specified in International norms.



PROTECTION TYPE

The protection against accidental human contact, ingress of dust or the entry of water is specified in IS: 4691 by an acronym of 2 letters followed by 2 numbers.

Scheme of IP index for Protection

1st Digit. Protection against harmful ingress of solid matter and dust.

2nd Digit. Protection against harmful entry of water

Rotomotive motors are with IP55 protection

	1 st number	2 st number
0	no protection	no protection
1	Protection against solid objects larger than 50mm	Protection against vertical water drops (condensation)
2	Protection against solid objects larger than 12mm	Protection against water drops fall upto 15 from the vertical
3	Protection against solid objects larger than 2.5mm	Protection against water drops upto 60 from the vertical
4	Protection against solid objects larger than 1mm	Protection against water splashes from all directions
5	Protection against dust (no deposits of harmful material)	Protection against water jet from a nozzle of 6.3mm D with a water capacity 12.5 lt/ min at a distance of maximum 3mt for 3 min
6*	Complete protection against ingress of dust.	Protection against jets of water comparable to heavy seas.

*OPTIONAL

WORKING CONDITIONS

HUMIDITY:

Rotomotive motors are suitable for operating in conditions of relative humidity between 30% and 95% (without condensation). Damaging effects of occasional condensation must be avoided by adequate equipment design or if necessary by additional measures (for example built in heating or air conditioning equipment, drain holes).

ALTITUDE AND TEMPERATURE:

The ratings indicated are at altitudes upto 1000mt above sea level and room temperature between +5°C and +45°C for motors having a rated power below 0.6KW or between -15°C and +45°C for motors having a rated power equal to or greater than 0.6KW (as per IS:325/ IEC 34-1).

Power output decreases by 10% for every 10°C increase in ambient temperature and 8% for each 1000mt increase in altitude.

It is not necessary to reduce the rated power if at an altitude higher than 1000mt and lower than 2000mt there is a max ambient temperature of 30°C or in altitudes from 2000mt to 3000mt there is a max ambient temperature of 19°C. This also holds true when the motors are operated at higher ambients, upto 50°C but at lower altitude.

VOLTAGE AND FREQUENCY VARIATION:

The maximum permissible variation in the supply voltage is +,-10%. Frequency variation of +,-5% is permissible and overall cumulative variation i.e the sum of variation of voltage and frequency +,-10% is allowed.

INSULATION:

The windings are vacuum impregnated under pressure with a layer of F class insulating enamel to ensure high resistance to electrical, thermal and mechanical stresses.

Slot insulation comprising of N.P.N insulating paper warps entirely around the coil side insulating the conductor from the body.

The phases are further isolated from each other by another layer of N.P.N phase separator paper to protect the motors from voltage peaks that usually occur when the motor is controlled by an inverter.

Maximum operating temperatures permitted for stator windings for each insulation class indicated on the motor name-plate.

Class	ΔT (°C)	T max (°C)
A	60+5 ⁰	105
E	75+5 ⁰	120
B	80+5 ⁰	130
F	105+5 ⁰	155
H	125	180

Rotomotive motors are designed to ensure that maximum temperature of the windings do not surpass the permissible temperature of their class even under S1 continuous duty service.

Almost all ratings of Rotomotive motors having class F insulation have the maximum temperature rise limited to the values permitted in Class B over an ambient of 50°C. Motors are suitable for 1.1 service factor with Class F temperature rise.



ROTOMOTIVE MOTORS PROTECTION

Protections for the motors must be chosen based on the specific running condition according to the standard EN 60204-1

- Protection for motors with a shaft power greater than or equal to 0.5 KW with continuous S1 duty. This protection may be achieved by means of a thermal cut out relay, which can automatically cut off the supply.

- Protection against peak currents by magnetic relay that controls a contactor or by fuses. These must be set to the locked rotor current.

- If the application requires protection against excessive speed of the electric motor in situations where the mechanical load may drive the electric motor itself and thereby create a hazardous situation.

- If special conditions or synchronized operation with other machines or parts of machines require it, protection against power failures or dips by means of a minimum voltage relay that controls a contactor.

The electrical protections on the motor power line may not be sufficient to protect against overloads. If the ambient temperature increases, the motor overheats but the electrical conditions do not change which inhibits line protections. Installing built-in thermal protections on the windings solves this problem.

- **PTO bimetallic device:**

This is a normally closed electromechanical device that opens electrically. When the threshold temperature is reached it automatically resets when the temperature falls below the threshold level. Bimetallic devices are available with various temperature ratings and without automatic reset as per EN 60204-1

- **PTC thermistor device:**

This device promptly changes its resistance once the threshold temperature is reached. ROTOMOTIVE motors from frame size 180 to 355L are equipped with 3 PTC thermistors in the winding with cut-off temperature of 150°C in Class F motors (standard) or 180°C in H Class motors.

- **PT100 device:**

This is a device that continuously changes its resistance according to the temperature. It is useful for continuous measurement of the winding temperatures using electronic equipment.



WIRING DIAGRAMS

Rotomotive three phase motors can be connected "Star" or "Delta".

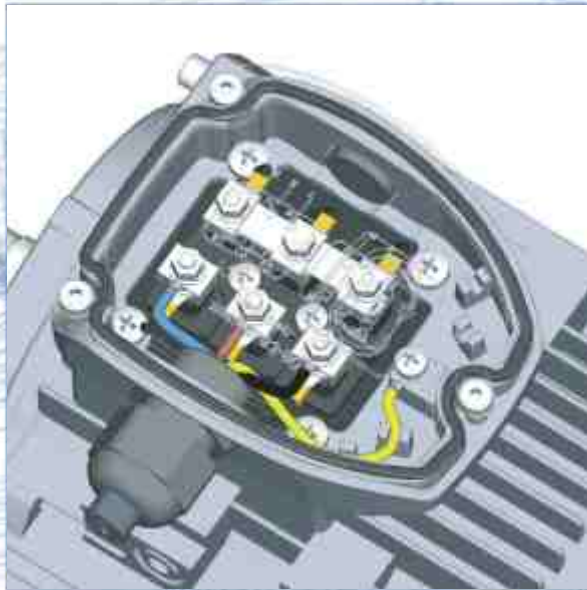

STAR CONNECTION:

Star connection is obtained by connecting together the terminals W2, U2, V2 and supplying the terminals U1, V1, W1

The phases current and voltage are respectively

$$I_{ph} = I_n$$

$$V_{ph} = V_n / \sqrt{3}$$

Where I_n is the supply line current and V_n is the supply line voltage of star connection

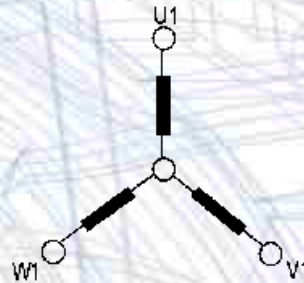

The following voltages and frequencies are possible by connection the three phase Rotomotive motors having S1 duty cycle in either Star OR Delta. Typical tolerances for motors of 415V, 50Hz rating are shown.

KW	Hz	Volts		
				Tolerance
Up to 2.2 KW	50 ± 5 %	230	400	+ 14 / - 7 %
		220	380	+ 15 / - 2 %
		240	415	+ 10 / - 10 %
	60 ± 5 %	260	440	+ 15 / - 6 %
		265	460	+ 10 / - 10 %
		280	480	+ 5 / - 14 %
Above 2.2 KW	50 ± 5 %	400	690	+ 14 / - 7 %
		380	660	+ 15 / - 2 %
		415	720	+ 10 / - 10 %
	60 ± 5 %	440	760	+ 15 / - 6 %
		460	795	+ 10 / - 10 %
		480	830	+ 5 / - 14 %

Voltages or tolerance other than these available on request

DELTA CONNECTION:

Delta connection is obtained by connecting the end of a phase with the beginning of the following one.

The phase current I_{ph} and the phase voltage V_{ph} are respectively:

$$I_{ph} = I_n / \sqrt{3}$$

$$V_{ph} = V_n$$

Where I_n and V_n are referred to Delta connection.

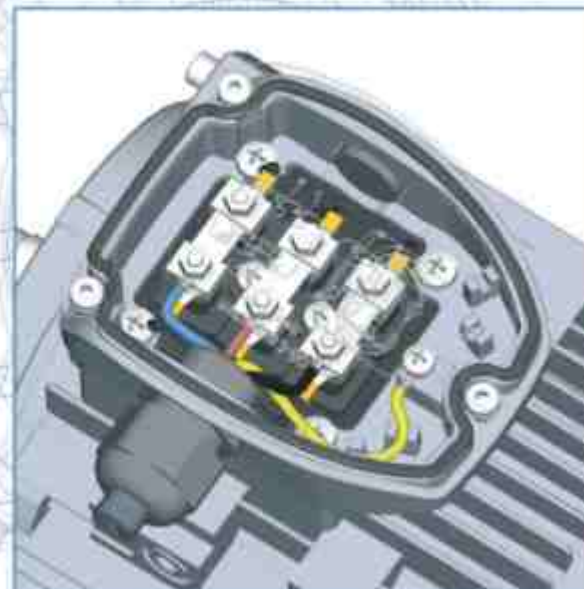
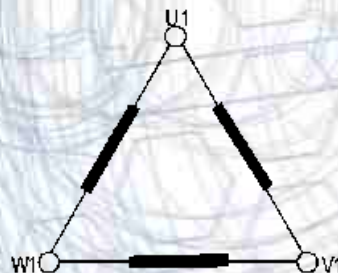

The general electrical specifications are listed in the performance charts that follow. To understand their contents, the following general definitions are provided.

Rated Power:
It is the Electrical equivalent of mechanical power measured at the shaft and expressed according to the terminology of International Standards Committees, in Watts or Kilowatts. However it is still common to refer to power in terms of Horsepower (HP).

Rated Voltage:
The voltage to be applied to the motor terminals in accordance with the specifications listed in the following tables

Frequency:
All electrical data in this catalogue refer to three phase induction motors at 50 Hz. These may be connected to 60 Hz taking into account the multiplier coefficients in the table below

Rated Current:
"In" is the rated current expressed in Amperes, drawn by the motor when supplied at rated voltage and delivering the rated power. In the following tables the rated currents are referred to a Voltage supply of 415V. For other voltage ratings, the absorbed rated current can be considered inversely proportional to the voltage supply. EX:

Volt	240	400	415	440	690
In	1.74	1.04	1.0	0.94	0.60

Over Load Current:
Rotomotive motors can also withstand temporary overloads, with current increases of 1.5 times the rated current for 2 minutes.

rated voltage at 50Hz	Volt at 60Hz	rated power W	rpm	In	Ia In	Ca Cn	Cmax Cn
240	240	1.1	1.2	1.15	0.9	0.9	0.9
240	260	1.2	1.2	1	1	1	1
415	415	1	1.2	1.2	0.8	0.8	0.8
415	440	1.06	1.2	1.1	0.87	0.87	0.87
415	460	1.2	1.2	1	1	1	1
415	480	1.25	1.2	1	1.1	1.1	1.1

for further information, see chapter "wiring diagrams" at page 9

Starting current (or locked rotor current):
In the performance charts the starting current "Is" is indicated as a multiple value of the rated current (Is/In)

Synchronous Speed:
Synchronous Speed (Ns) is expressed in rpm and it is obtained by the formula

$$N_s = \frac{120 \times f}{P}$$
 f= supply frequency Hz
 P= number of poles pairs

Rated Torque:
Cn is expressed in Nm and it corresponds to the rated power and rated rpm. It is given by the multiplication of the force for the arm (distance) and it is measured in Nm because the force is expressed in Newton and the distance in meters The rated torque value is obtained by the formula

$$C_n \text{ (Nm)} = \frac{9550 \times P_n}{n}$$
 Pn = Rated Power in KW
 N = Rated rotation speed in rpm

Starting torque (or locked rotor torque):
Cs is the torque that the motor can develop with the rotor at a standstill and the rated power supply.

Maximum torque (Pull out Torque):
Cmax is the maximum torque developed by the motor at the rated power supply at a certain speed.

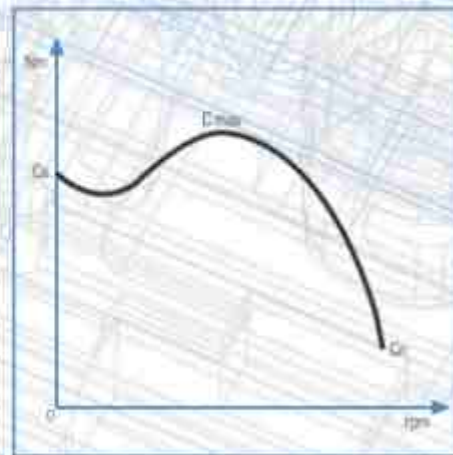

It represents also the value of the stall torque/pull out torque after which the motor stops.

In the following performance charts, it is indicated the relation between maximum torque and rated torque and maximum torque (Cmax / Cn)

Efficiency:
η is expressed in % and it is given by the relation between the output power and the addition of output Power and the electric losses of the motor, that is the input power consumed by the motor. The electric motors losses are mainly of two kinds: copper losses and iron losses. These losses are lost in form of heat. Higher efficiency means energy savings, lower heating, longer life of insulating materials.

Power factor or cos Ø:
It represents the cosine of the voltage and current gap angle

Noise:
The noise is expressed in dB (A). The measurement must be taken in accordance with the standard IS: 12065/ ISO 1680-2, in order to find the Sound Power level LwA measured at a distance of 1m from the machine. This standard describes the acoustic Power limits to be followed, indicating the maximum sound power level LwA. The noise values indicated in the performance charts that follow are for the motors operating in no-load condition, supplied at 50Hz and with a tolerance of +3 dB (A)

The moment of inertia can be calculated in this way:

$$J = \frac{1}{2} M R^2$$
 Where M (Kg) is the mass which is rotated, while R (m) is the radius of the rotor/ rotating mass.

TOLERANCES

The data of each motor are specified in this catalogue like requested by the norm IS: 325. This describes in particular the following tolerance:

Characteristic	Tolerance
Efficiency (Output Power input Power)	-15% di [1- n]
Power factor	1/ 6 of [1- cos Ø] min. 0.02 max 0.07
Locked rotor torque	-15% of the guaranteed torque +25% of the guaranteed torque
Maximum torque	-10% of the guaranteed torque, if torque is not less than 1.5- 1.6 the rated torque
Noise	+3dB(A)





PERFORMANCE CHART



2 Poles asynchronous speed 3000 rpm

Power KW	Power HP	Type	Frame	rpm	Current In (A)	Current Is/In	Torque Cn (Nm)	Torque Cs/Cn	Torque Cmax/Cn	Efficiency 100%	Efficiency 75%	Power Factor 100%	Power Factor 75%	Noise Level (dB)	J Kgm ²	Kgs
0.09	0.12	56A-2	56	2740	0.3	4.5	0.31	2.2	2.3	62.0	61.0	0.77	0.71	65	0.00010	3.5
0.12	0.18	56B-2	56	2740	0.3	4.5	0.42	2.2	2.3	64.0	63.0	0.78	0.72	65	0.00020	3.6
0.18	0.25	63A-2	63	2740	0.5	4.5	0.63	2.4	2.4	66.0	66.0	0.80	0.74	68	0.00031	4.5
0.25	0.35	63B-2	63	2750	0.6	4.5	0.87	2.5	2.6	70.0	69.0	0.81	0.75	68	0.00040	4.7
0.37	0.5	71A-2	71	2810	0.9	5.5	1.26	2.6	2.8	72.0	71.0	0.79	0.73	70	0.00055	6.0
0.55	0.75	71B-2	71	2780	1.3	5.5	1.89	3.0	3.5	73.0	73.0	0.79	0.73	70	0.00060	6.3
0.75	1	80A-2	80	2850	1.7	5.5	2.51	2.8	3.0	78.0	77.0	0.79	0.74	73	0.00075	10
1.1	1.5	80B-2	80	2850	2.4	5.5	3.7	2.6	2.9	80.0	79.0	0.80	0.75	73	0.00090	11
1.5	2	90S-2	90S	2850	3.2	5.5	5.03	2.8	3.0	81.0	81.0	0.80	0.75	75	0.00120	13
2.2	3	90L-2	90L	2840	4.4	5.5	7.40	2.3	2.6	82.5	82.0	0.85	0.80	75	0.00140	14
3.7	5	100L-2	100L	2880	7.1	6.0	12.28	2.3	2.6	85.0	84.0	0.85	0.81	76	0.00400	27
5.5	7.5	132SA-2	132S	2900	10.2	6.0	18.12	1.8	2.6	86.0	85.0	0.87	0.83	80	0.01090	40
7.5	10	132SB-2	132S	2900	13.3	6.0	24.71	1.8	2.8	87.0	86.0	0.90	0.87	80	0.01260	45
9.3	12.5	160MA-2	160M	2930	17.0	6.0	30.33	2.1	2.2	87.7	87.0	0.87	0.84	86	0.03770	110
11	15	160MB-2	160M	2930	19.9	6.0	35.87	2.2	2.3	88.5	87.5	0.87	0.84	86	0.03770	110
15	20	160MC-2	160M	2930	26.5	6.0	48.92	2.2	2.3	89.5	88.5	0.88	0.85	86	0.04990	120
18.5	25	160L-2	160L	2930	32.1	6.0	60.33	2.2	2.3	90.0	89.0	0.89	0.86	86	0.05500	135
22	30	180M-2	180M	2940	38.0	7.0	71.50	2.0	2.3	90.5	89.5	0.89	0.86	89	0.07500	165
30	40	200LA-2	200L	2950	53.7	7.0	97.17	2.0	2.3	91.4	90.3	0.85	0.83	92	0.12400	217
37	50	200LB-2	200L	2950	66.3	7.0	119.84	2.0	2.3	92.0	90.8	0.84	0.83	92	0.13900	243
45	60	225M-2	225M	2970	76.0	7.0	144.77	2.0	2.3	92.5	90.9	0.89	0.85	92	0.23300	320
55	75	250M-2	250M	2970	95.7	7.0	176.94	2.0	2.3	93.0	91.9	0.86	0.84	93	0.31200	390
75	100	280S-2	280S-2	2970	129.6	7.0	241.29	2.0	2.3	93.6	93.0	0.86	0.84	94	0.57900	540
90	120	280M-2	280M	2970	148.2	7.0	289.54	2.0	2.3	93.9	93.0	0.90	0.85	94	0.67500	590
110	150	315S-2	315S	2975	178.9	7.0	353.29	1.8	2.2	94.0	93.0	0.91	0.86	96	1.18000	880
132	180	315MA-2	315M	2975	213.6	7.0	423.95	1.8	2.2	94.5	93.5	0.91	0.86	96	1.82000	1000
160	215	315LA-2	315L	2975	255.8	7.0	513.88	1.8	2.2	94.8	93.5	0.92	0.87	99	2.08000	1055
200	270	315LB-2	315L	2975	319.0	7.0	642.35	1.8	2.2	94.8	93.8	0.92	0.87	99	2.38000	1110
250	340	355M-2	355M	2975	396.7	7.0	802.94	1.8	2.2	95.3	94.0	0.92	0.88	103	3.00000	1900
315	430	355L-2	355L	2975	498.3	7.0	1011.70	1.8	2.2	95.6	94.2	0.92	0.88	103	3.50000	2300

● Efficiency is without seals. ● All these performance values are declared at rated voltage 415 & frequency 50 Hz and are subjected to tolerances as per IS : 325 & IS : 12615.



PERFORMANCE CHART



4 Poles asynchronous speed 1500 rpm

Power KW	Power HP	Type	Frame	rpm	Current In [A]	Current Is/In	Torque Cn (Nm)	Torque Cs/Cn	Torque Cmax/Cn	Efficiency 100%	Efficiency 75%	Power Factor 100%	Power Factor 75%	Noise Level (dB)	J Kg ^m ²	Kgs
0.06	0.09	56A-4	56	1325	0.2	4.0	0.43	2.0	2.1	56.0	55.5	0.69	0.61	52	0.00015	3.5
0.09	0.12	56B-4	56	1325	0.3	4.0	0.65	2.0	2.1	58.0	57.5	0.70	0.61	52	0.00015	3.6
0.12	0.18	63A-4	63	1350	0.4	4.0	0.85	2.2	2.2	60.0	60.0	0.70	0.64	52	0.00030	4.5
0.18	0.25	63B-4	63	1380	0.5	4.0	1.25	2.4	2.4	67.0	66.0	0.70	0.64	52	0.00040	4.7
0.25	0.35	71A-4	71	1350	0.7	4.0	1.77	2.3	2.3	68.0	67.0	0.70	0.62	60	0.00050	6.0
0.37	0.5	71B-4	71	1350	1.0	4.0	2.60	2.3	2.3	71.0	71.0	0.70	0.60	60	0.00080	6.3
0.55	0.75	80A-4	80	1380	1.5	4.5	3.81	2.5	3.0	74.0	74.0	0.71	0.65	65	0.00180	10
0.75	1	80B-4	80	1385	1.9	4.5	5.17	2.5	3.0	75.5	75.0	0.71	0.64	65	0.00210	11
1.1	1.5	90S-4	90S	1390	2.7	5.0	7.56	2.1	2.2	78.0	77.5	0.73	0.67	61	0.00230	13
1.5	2	90L-4	90L	1400	3.5	5.0	10.24	2.8	3.0	78.5	77.5	0.76	0.70	72	0.00270	14
2.2	3	100LA-4	100L	1445	4.9	5.0	14.55	2.8	2.8	82.0	82.0	0.76	0.72	64	0.00670	25
3.7	5	112M-4	112M	1445	7.9	5.0	24.47	2.1	2.2	85.0	84.5	0.77	0.73	65	0.00950	28
5.5	7.5	132S-4	132S	1445	11.3	5.5	36.37	1.9	2.2	86.5	86.5	0.78	0.72	71	0.02140	45
7.5	10	132MA-4	132M	1455	15.0	5.5	49.25	2.0	2.2	87.0	87.0	0.80	0.74	71	0.02960	55
9.3	12.5	160MA-4	160M	1460	17.6	6.0	60.86	2.2	2.3	87.7	87.0	0.84	0.80	75	0.07470	118
11	15	160MB-4	160M	1460	20.4	6.0	71.99	2.2	2.3	88.4	88.0	0.85	0.80	75	0.07470	118
15	20	160L-4	160L	1470	27.5	6.0	97.50	2.2	2.3	89.4	88.5	0.85	0.80	75	0.09180	132
18.5	25	180M-4	180M	1470	32.1	6.5	120.25	2.2	2.3	90.0	89.5	0.89	0.84	76	0.13900	164
22	30	180L-4	180L	1470	38.4	6.5	143.0	2.2	2.3	90.5	90.0	0.88	0.83	76	0.15800	182
30	40	200L-4	200L	1470	51.9	6.5	195.0	2.2	2.3	91.4	91.0	0.88	0.84	79	0.26200	245
37	50	225S-4	225S	1480	64.3	6.5	238.9	2.2	2.3	92.0	91.5	0.87	0.83	81	0.40600	258
45	60	225M-4	225M	1480	76.0	6.5	290.5	2.2	2.3	92.5	92.0	0.89	0.84	81	0.46900	290
55	75	250M-4	250M	1480	92.4	6.5	355.1	2.2	2.3	93.0	92.5	0.89	0.84	81	0.66000	388
75	100	280S-4	280S	1480	125.3	7.0	484.2	2.2	2.3	93.6	93.0	0.89	0.85	86	1.12000	510
90	120	280M-4	280M	1480	149.8	7.0	581.0	2.2	2.3	93.9	93.2	0.89	0.86	86	1.46000	606
110	150	315S-4	315S	1480	182.2	6.5	710.2	2.1	2.2	94.4	94.0	0.89	0.86	93	3.11000	910
132	180	315M-4	315M	1480	217.9	6.5	852.2	2.1	2.2	94.7	94.0	0.89	0.86	93	3.62000	1000
160	220	315LA-4	315L	1480	264.1	6.5	1033.0	2.1	2.2	95.0	94.0	0.89	0.86	97	4.13000	1055
200	270	315LB-4	315L	1480	329.1	6.5	1291.2	2.1	2.2	95.0	94.2	0.89	0.86	97	4.73000	1128
250	340	355M-4	355M	1480	405.5	6.5	1614.0	2.1	2.2	95.3	94.5	0.90	0.86	101	6.50000	1700
315	430	355L-4	355L	1480	509.3	6.5	2033.7	2.1	2.2	95.6	94.8	0.90	0.86	101	8.20000	1900

● Efficiency is without seals. ● All these performance values are declared at rated voltage 415 & frequency 50 Hz and are subjected to tolerances as per IS : 325 & IS : 12615.



PERFORMANCE CHART



6 Poles asynchronous speed 1000 rpm

Power KW	Power HP	Type	Frame	rpm	Current In [A]	Current Is/In	Torque Cn (Nm)	Torque Cs/Cn	Torque Cmax/Cn	Efficiency 100%	Efficiency 75%	Power Factor: 100%	Power Factor 75%	Noise Level [dB]	J Kg ^m ²	Kgs
0.18	0.25	71A-6	71	900	0.6	4.0	1.91	1.9	2.0	60.0	60.0	0.68	0.60	52	0.00110	6
0.25	0.35	71B-6	71	900	0.9	4.0	2.65	1.9	2.0	60.0	60.0	0.68	0.61	52	0.00140	6.3
0.37	0.5	80A-6	80	900	1.1	4.0	3.82	1.9	2.0	67.0	67.0	0.69	0.64	54	0.00160	10
0.55	0.75	80B-6	80	900	1.6	4.0	5.84	1.9	2.1	69.0	69.0	0.70	0.65	54	0.00190	11
0.75	1	90S-6	90S	920	2.0	4.0	7.79	2.0	2.1	72.0	72.0	0.71	0.65	57	0.00290	13
1.1	1.5	90L-6	90L	920	2.8	4.5	11.42	2.0	2.1	76.0	75.0	0.71	0.65	57	0.00350	14
1.5	2	100L-6	100L	920	3.8	4.5	15.58	2.0	2.1	77.0	76.0	0.72	0.65	61	0.00690	23
2.2	3	112M-6	112M	930	5.2	4.0	22.60	1.9	2.0	81.0	80.0	0.74	0.67	65	0.01400	25
3.7	5	132S-6	132S	950	8.3	5.0	37.21	1.9	2.1	85.0	84.0	0.73	0.65	69	0.03570	44
5.5	7.5	132M-6	132M	960	12.1	5.5	54.74	1.8	2.1	85.5	84.5	0.74	0.69	69	0.04490	55
7.5	10	160M-6	160M	965	16.1	5.5	74.26	2.0	2.1	86.5	86.0	0.75	0.69	73	0.08100	78
9.3	12.5	160LA-6	160L	965	19.6	5.5	92.08	2.0	2.1	87.0	86.5	0.76	0.70	73	0.11600	90
11	15	160LB-6	160L	970	22.3	5.5	108.35	2.0	2.1	88.0	87.5	0.78	0.71	73	0.11600	90
15	20	180L-6	180L	970	28.9	6.5	147.76	2.0	2.1	89.0	88.5	0.81	0.74	73	0.20700	160
18.5	25	200LA-6	200L	970	35.5	6.5	182.23	2.0	2.1	89.5	89.0	0.81	0.75	76	0.31500	217
22	30	200LB-6	200L	970	41.0	6.5	216.71	2.0	2.1	90.0	89.5	0.83	0.75	76	0.36000	244
30	40	225M-6	225M	980	54.6	6.5	292.50	2.0	2.1	91.0	90.0	0.84	0.77	76	0.54700	295
37	50	250M-6	250M	980	66.2	6.5	360.75	2.0	2.1	91.5	91.0	0.85	0.79	78	0.84300	365
45	60	280S-6	280S	980	79.1	6.5	438.75	2.0	2.1	92.0	91.5	0.86	0.80	80	1.39000	500
55	75	280M-6	280M	980	96.2	6.5	536.25	2.0	2.1	92.5	92.0	0.86	0.80	85	1.65000	545
75	100	315S-6	315S	980	130.5	6.5	731.25	2.0	2.0	93.0	92.5	0.86	0.80	85	4.11000	810
90	120	315MA-6	315M	980	156.1	6.5	877.49	2.0	2.0	93.3	93.0	0.86	0.80	85	4.78000	900
110	150	315LA-6	315L	980	190.3	6.5	1072.49	2.0	2.0	93.5	93.0	0.86	0.80	85	5.45000	1010
132	180	315LB-6	315L	980	228.4	6.5	1286.99	2.0	2.0	93.8	93.0	0.86	0.80	85	6.12000	1140
160	220	355MA-6	355M	980	269.1	6.5	1559.99	1.9	2.0	94.0	93.5	0.88	0.80	92	9.50000	1550
200	270	355MB-6	355M	980	334.6	6.5	1949.99	1.9	2.0	94.5	93.5	0.88	0.80	92	10.40000	1600
250	340	355L-6	355L	980	418.2	6.5	2437.48	1.9	2.0	94.5	93.5	0.88	0.80	92	12.40000	1700

● Efficiency is without seals. ● All these performance values are declared at rated voltage 415 & frequency 50 Hz and are subjected to tolerances as per IS : 325 & IS : 12615.



PERFORMANCE CHART



8 Poles asynchronous speed 750 rpm

Power KW	Power HP	Type	Frame	rpm	Current In [A]	Current Is/In	Torque Cn (Nm)	Torque Cs/Cn	Torque Cmax/Cn	Efficiency 100%	Efficiency 75%	Power Factor 100%	Power Factor 75%	Noise Level [dB]	J Kg ^{m²}	Kg
1.5	2	112M-8	112M	690	4.0	5.0	20.77	1.8	2.0	75.0	74.5	0.69	0.60	61	0.02450	28
2.2	3	132S-8	132S	705	5.5	6.0	29.82	1.8	2.0	78.0	77.0	0.71	0.65	64	0.03140	45
3.7	5	160MA-8	160M	720	8.7	6.0	49.10	1.9	2.0	81.0	80.0	0.73	0.66	68	0.07530	105
5.5	7.5	160MB-8	160M	720	12.5	6.0	72.99	2.0	2.0	83.0	82.0	0.74	0.67	68	0.09310	115
7.5	10	160L-8	160L	720	16.3	6.0	99.53	2.0	2.0	85.5	85.0	0.75	0.67	68	0.12600	135
11	15	180L-8	180L	730	23.0	5.5	143.98	2.0	2.0	87.5	87.0	0.76	0.68	70	0.20300	160
15	20	200L-8	200L	730	31.2	6.6	196.33	2.0	2.0	88.0	87.5	0.76	0.68	73	0.33900	235
18.5	25	225S-8	225S	730	38.1	6.6	242.15	1.9	2.0	89.0	88.5	0.76	0.68	73	0.49100	242
22	30	225M-8	225M	730	43.4	6.6	287.96	1.9	2.0	90.5	90.0	0.78	0.70	73	0.54700	285
30	40	250M-8	250M	730	58.1	6.6	392.67	1.9	2.0	91.0	90.0	0.79	0.72	75	0.84300	390
37	50	280S-8	280S	730	71.2	6.6	484.29	1.9	2.0	91.5	90.5	0.79	0.73	76	1.93000	500
45	60	280M-8	280M	735	86.1	6.6	585.00	1.8	2.0	92.0	91.5	0.79	0.73	76	1.65000	580
55	75	315S-8	315S	735	101.8	6.6	715.00	1.8	2.0	92.8	92.0	0.81	0.75	82	4.79000	790
75	100	315MA-8	315M	735	138.5	6.6	974.99	1.8	2.0	93.0	92.5	0.81	0.75	82	5.58000	970
90	120	315MB-8	315M	735	162.8	6.6	1169.99	1.8	2.0	93.8	93.0	0.82	0.76	82	6.37000	1055
110	150	315MC-8	315M	735	198.5	6.6	1429.99	1.8	2.0	94.0	93.5	0.82	0.76	82	7.23000	1118

● Efficiency is without seals. ● All these performance values are declared at rated voltage 415 & frequency 50 Hz and are subjected to tolerances as per IS : 325 & IS : 12615.



PERFORMANCE CHART



IE2, High efficiency class IEC 60034-30

Power KW	Power HP	Type	Frame	rpm	Current In (A)	Current Is/In	Torque Cn (Nm)	Torque Cs/Cn	Torque Cmax/Cn	Efficiency 100%	Efficiency 75%	Power Factor. 100%	Power Factor 75%	Noise Level (dB)	J Kg ^m ²	Kgs
2 Poles asynchronous speed 3000 rpm																
0.75	1	80A-2	80	2850	1.7	5.5	2.51	2.8	3.0	78.0	77.0	0.79	0.74	73	0.00075	10
1.1	1.5	80B-2	80	2850	2.4	5.5	3.70	2.6	2.9	80.0	79.0	0.80	0.75	73	0.00090	11
1.5	2	90S-2	90S	2850	3.2	5.5	5.03	2.8	3.0	81.3	81.0	0.80	0.75	75	0.00120	13
2.2	3	90L-2	90L	2840	4.3	5.5	7.40	2.3	2.6	83.2	82.5	0.85	0.80	75	0.00140	14
3.7	5	100L-2	100L	2880	7.1	6.0	12.28	2.3	2.6	85.9	85.0	0.85	0.81	76	0.00400	27
5.5	7.5	132SA-2	132S	2900	10.2	6.0	18.12	1.8	2.6	87.2	86.6	0.86	0.81	80	0.01190	40
7.5	10	132SB-2	132S	2900	13.3	6.5	24.70	1.8	2.8	88.2	87.7	0.89	0.87	80	0.01260	45
11	15	160MA-2	160M	2910	19.4	6.5	36.10	2.3	2.5	89.5	89.0	0.88	0.83	86	0.04990	120
15	20	160MB-2	160M	2910	26.5	6.5	49.22	2.3	2.5	90.4	90.1	0.87	0.86	86	0.05500	135
18.5	25	160L-2	160L	2910	31.7	6.5	60.71	2.3	2.5	91.1	90.7	0.89	0.86	86	0.06600	155
22	30	180M-2	180M	2940	37.6	7.0	71.50	2.0	2.3	91.4	90.4	0.89	0.86	89	0.07500	165
30	40	200LA-2	200L	2950	53.3	7.0	97.17	2.0	2.3	92.2	91.1	0.85	0.83	92	0.12400	217
37	50	200LB-2	200L	2950	66.2	7.0	119.84	2.0	2.3	92.5	91.3	0.84	0.83	92	0.13900	243
45	60	225M-2	225M	2970	75.6	7.0	144.77	2.0	2.3	93.0	91.4	0.89	0.85	92	0.23300	320
4 Poles asynchronous speed 1500 rpm																
0.75	1	80-4	80	1390	1.8	4.5	5.15	2.5	3.0	79.6	79.1	0.72	0.64	65	0.00220	12.5
1.1	1.5	90S-4	90S	1410	2.5	5.0	7.45	2.1	2.2	81.4	80.6	0.75	0.7	61	0.00270	14
1.5	2	90L-4	90L	1410	3.4	5.0	10.16	2.8	3.0	82.9	82.5	0.74	0.7	72	0.00410	16
2.2	3	100L-4	100L	1440	4.5	5.0	14.60	2.8	2.9	84.4	84.4	0.80	0.74	64	0.00670	27
3.7	5	112M-4	112M	1425	7.6	5.0	24.79	2.1	2.2	86.6	86.3	0.78	0.73	65	0.01500	35
5.5	7.5	132S-4	132S	1445	11.2	5.5	36.37	1.9	2.2	87.8	87.4	0.78	0.72	71	0.02140	45
7.5	10	132M-4	132M	1455	14.7	5.5	49.25	2.0	2.2	88.7	88.5	0.80	0.74	71	0.02960	55
11	15	160M-4	160M	1460	20.0	6.0	71.99	2.2	2.3	89.8	89.0	0.85	0.80	75	0.07470	118
15	20	160L-4	160L	1470	27.0	6.0	97.50	2.2	2.3	90.8	89.8	0.85	0.80	75	0.09180	132
18.5	25	180M-4	180M	1470	31.7	6.5	120.25	2.2	2.3	91.2	90.7	0.89	0.84	76	0.13900	164
22	30	180L-4	180L	1470	38.0	6.5	143.00	2.2	2.3	91.6	91.0	0.88	0.83	76	0.15800	182
30	40	200L-4	200L	1470	51.4	6.5	195.00	2.2	2.3	92.3	91.8	0.88	0.84	79	0.26200	245
37	50	225S-4	225S	1480	63.8	6.5	238.90	2.2	2.3	92.8	92.3	0.87	0.83	81	0.40600	258
45	60	225M-4	225M	1480	75.4	6.5	290.50	2.2	2.3	93.3	92.8	0.89	0.84	81	0.46900	290
6 Poles asynchronous speed 1000 rpm																
0.75	1	90S-6	90S	930	1.9	4.0	7.75	2.1	2.3	76.0	75.0	0.71	0.62	57	0.00350	14
1.1	1.5	90L-6	90L	930	2.8	4.0	11.30	2.2	2.4	78.3	78.0	0.71	0.62	57	0.00390	15
1.5	2	100L-6	100L	940	3.7	4.5	15.25	2.1	2.3	79.9	79.7	0.71	0.62	61	0.00850	25
2.2	3	112M-6	112M	940	5.1	5.5	22.36	2.1	2.5	81.9	81.7	0.73	0.64	65	0.01600	28
3.7	5	132S-6	132S	950	8.3	5.0	37.21	1.9	2.1	85.0	84.0	0.73	0.65	69	0.03570	44
5.5	7.5	132M-6	132M	960	12.0	5.5	54.74	1.8	2.1	86.5	85.5	0.74	0.69	69	0.04490	55
7.5	10	160M-6	160M	965	15.9	5.5	74.26	2.0	2.1	87.3	86.8	0.75	0.69	69	0.08100	78
11	15	160L-6	160L	965	21.5	5.5	108.85	2.1	2.4	89.0	88.5	0.80	0.71	73	0.12860	99
15	20	180L-6	180L	970	28.7	6.5	147.76	2.0	2.1	89.8	89.2	0.81	0.74	73	0.20700	160
18.5	25	200LA-6	200L	970	35.1	6.5	182.23	2.0	2.1	90.6	90.0	0.81	0.75	76	0.31500	217
22	30	200LB-6	200L	970	40.5	6.5	216.71	2.0	2.1	91.1	90.6	0.83	0.75	76	0.36000	244
30	40	225M-6	225M	980	54.1	6.5	292.50	2.0	2.1	91.8	90.8	0.84	0.77	76	0.54700	295

● Efficiency is without seals. ● All these performance values are declared at rated voltage 415 & frequency 50 Hz and are subjected to tolerances as per IS : 325 & IS : 12615.



Power KW	Power HP	Type	Frame	rpm	Current In [A]	Current Is/In	Torque Cn [Nm]	Torque Cs/Cn	Torque Cmax/Cn	Efficiency 100%	Efficiency 75%	Power Factor 100%	Power Factor 75%	Noise Level [dB]	J Kg ^m ²	Kgs
2 Poles asynchronous speed 3000 rpm																
0.75	1	80A-2	80	2850	1.61	5.5	2.51	2.8	3.0	80.9	79.9	0.80	0.74	73	0.00090	11
1.1	1.5	80B-2	80	2810	2.37	5.5	3.71	2.8	3.0	82.9	81.0	0.78	0.76	75	0.00105	12.5
1.5	2	90S-2	90S	2860	3.13	5.5	5.01	2.8	3.0	84.5	84.0	0.79	0.73	75	0.00120	13
2.2	3	90L-2	90L	2860	4.24	5.5	7.35	2.3	2.6	85.9	85.0	0.84	0.80	75	0.00215	18
3.7	5	100L-2	100L	2870	7.04	6.0	12.31	2.3	2.6	88.1	87.6	0.83	0.78	76	0.00420	27
5.5	7.5	132SA-2	132S	2900	10.12	6.0	18.11	1.8	2.6	90.0	89.2	0.84	0.81	80	0.01190	40
7.5	10	132SB-2	132S	2900	13.25	6.5	24.70	1.8	2.8	90.5	90.0	0.87	0.84	80	0.01260	45
11	15	160MA-2	160M	2930	19.25	6.5	36.10	2.3	2.5	91.4	90.8	0.87	0.85	86	0.04990	120
15	20	160MB-2	160M	2930	26.38	6.5	48.89	2.3	2.5	92.0	91.5	0.86	0.84	86	0.05500	135
18.5	25	160L-2	160L	2930	31.59	6.5	60.29	2.3	2.5	92.6	92.0	0.88	0.86	86	0.06600	155
22	30	180M-2	180M	2940	37.48	7.0	71.50	2.0	2.3	92.8	91.8	0.88	0.86	89	0.07650	168
30	40	200LA-2	200L	2940	52.57	7.0	97.45	2.0	2.3	93.4	92.3	0.85	0.83	92	0.12640	221
37	50	200LB-2	200L	2950	65.33	7.0	119.84	2.0	2.3	93.8	92.6	0.84	0.83	92	0.14178	248
45	60	225M-2	225M	2970	74.75	7.0	144.77	2.0	2.3	94.1	92.5	0.89	0.85	92	0.23766	326
4 Poles asynchronous speed 1500 rpm																
0.75	1	80-4	80	1390	1.75	4.5	5.15	2.5	3.0	82.6	82.3	0.72	0.64	65	0.00220	12.5
1.1	1.5	90S-4	90S	1420	2.42	5.0	7.40	2.1	2.2	84.2	83.6	0.75	0.70	61	0.00270	14
1.5	2	90L-4	90L	1410	3.26	5.0	10.16	2.8	3.0	85.4	84.7	0.75	0.71	72	0.00410	16
2.2	3	100L-4	100L	1440	4.36	5.0	14.59	2.8	2.9	86.7	86.4	0.81	0.74	64	0.00670	27
3.7	5	112M-4	112M	1430	7.44	5.0	24.71	2.1	2.2	88.7	88.2	0.78	0.72	65	0.01500	35
5.5	7.5	132S-4	132S	1455	10.38	5.5	36.10	1.9	2.2	89.9	89.4	0.82	0.77	71	0.02960	55
7.5	10	132M-4	132M	1460	14.08	6.0	49.05	2.6	3.0	90.4	90.0	0.82	0.77	71	0.03100	59
11	15	160M-4	160M	1460	19.91	6.5	71.95	2.2	2.3	91.5	91.0	0.84	0.80	75	0.09180	125
15	20	160L-4	160L	1470	26.63	6.5	97.44	2.2	2.3	92.2	91.5	0.85	0.83	75	0.11000	140
18.5	25	180M-4	180M	1470	31.23	6.5	120.25	2.2	2.3	92.6	92.0	0.89	0.84	76	0.14462	167
22	30	180L-4	180L	1470	38.19	6.5	143.00	2.2	2.3	93.2	92.6	0.86	0.82	76	0.16438	189
30	40	200L-4	200L	1470	51.25	6.5	195.00	2.2	2.3	93.6	92.2	0.87	0.84	79	0.27258	255
37	50	225S-4	225S	1480	63.01	6.5	238.90	2.2	2.3	93.9	93.2	0.87	0.84	81	0.42240	268
45	60	225M-4	225M	1480	74.60	6.5	290.50	2.2	2.3	94.3	92.8	0.89	0.85	81	0.48795	301
6 Poles asynchronous speed 1000 rpm																
0.75	1	90S-6	90S	930	1.86	4.0	7.70	2.1	2.4	78.9	78.0	0.71	0.64	57	0.00350	14
1.1	1.5	90L-6	90L	930	2.62	4.0	11.29	2.2	2.4	81.0	79.8	0.72	0.63	57	0.00390	15
1.5	2	100L-6	100L	940	3.56	4.5	15.24	2.1	2.3	82.5	81.0	0.71	0.62	61	0.00850	25
2.2	3	112M-6	112M	940	4.97	5.5	22.35	2.1	2.5	84.3	83.3	0.73	0.64	65	0.01600	28
3.7	5	132S-6	132S	960	8.12	6.0	36.80	2.0	2.4	86.8	86.0	0.73	0.65	69	0.03920	49
5.5	7.5	132M-6	132M	965	11.75	5.5	54.43	2.3	2.5	88.0	87.0	0.74	0.69	69	0.04900	59

● Efficiency is without seals. ● All these performance values are declared at rated voltage 415 & frequency 50 Hz and are subjected to tolerances as per IS : 325 & IS : 12615.

world IEC 60034 - 30	IE - 1 standard efficiency	IE - 2 high efficiency	IE - 3 premium efficiency
Europe 50 Hz CEMEP	comparable to EFF - 2	comparable to EFF - 1	

OPTIONAL ACCESSORIES & FEATURES

ASSISTED POWER COOLING

Three-phase 415/50, 415/60, IP 55, with separate terminal box



For applications where the motor will be operated below a frequency of 25Hz and above 60 Hz, the appropriate assisted power cooling must be mounted as there are too many variables involved to determine the various possible thermal duties, and thus the temperatures reached by the motors

TYPE	POWER W	CAPACITY m ³ /h	L
63	21	140	300
71	30	300	320
80	35	350	366
90S	50	500	400
90L	50	500	425
100	65	650	468
112	65	1000	450
132S	90	880	570
132M	90	880	610
160M	90	1100	710
160L	90	1100	765
180M	100	1200	805
180L	100	1200	845
200L	180	2500	910
225S	200	3800	1035
225M	200	3800	1040
250M	320	4200	1110
280S	370	5000	1160
280M	370	5000	1210
315S	500	6000	1410
315M	500	6000	1440
315L	500	6000	1550
355M	600	6500	1735
355L	600	6500	1765

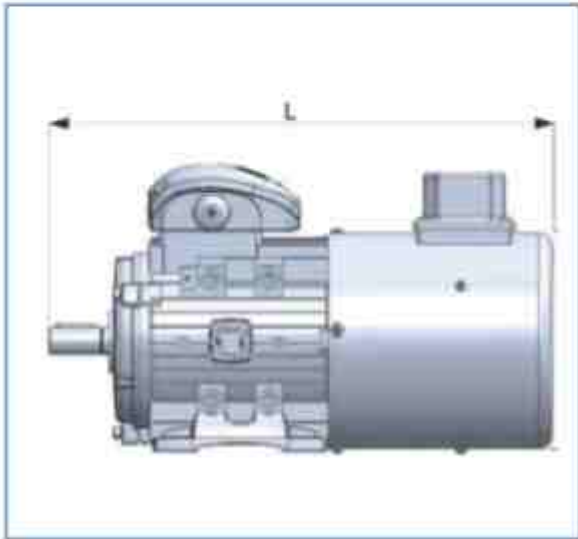

OPTIONAL FEATURES OFFERED IN EFF2, IE2 & IE3 MOTORS.

Mechanical	
Special mounting	Non standard mounting dimensions
C.I. Body	100, 112 & 132 Frame size
Non Standard shaft material	EN24
Non Standard shaft extension	
Non Standard T. Box location	RHS/LHS or TOP
Non Standard Cable entries	
Motors with Thermal protection	PTC Thermistors, BTD Thermostat, RTD etc.
Non standard bearings	Roller bearings on driving end side
Higher Degree of protection than IP55	IP56, IP65, IP66
Low vibration motors	Precision class vibration levels(A,B or C) as per IS : 12075
Non standard paint	Epoxy paint, Poly urethane paint
Special accessories like arrow plate, Aux. name plate etc.	
Forced cooling arrangement 71 frame onwards	
Surface cooled motors (TENV)	
Motors with clean flow cowl arrangement	
Motors with flying leads	
Space heater	160 Frame onwards

Electrical	
Non standard voltage	27 to 720V
Non standard Frequency	50 to 150 Hz
Motors with wide variation in following parameters	
a. Voltage variation	>10%
b. Frequency Variation	>5%
c. Motors with higher than 8 pole	10pole,12pole etc.
d. Dual speed motors	2 / 4 Pole & 4 / 8 Pole
Class H insulation scheme	
Motors for high inertia load	
Motors with high slip	
Motors with intermittent duties	
Motors with service factor higher than 1	i.e. 1.2 service factor with Class F temperature rise of 50°C as a special construction against specific orders only for few ratings.

ENCODER

Motors with encoder or special shaft configurations for encoder mounting are available upon request. In this case assisted power cooling is also available, supported by brackets on the fan cover

CUSTOM BUILT MOTOR

Rotomotive Design Engineers are well versed in the art & science of product / process design. They use tools like CAD/CAM extensively in their work. The analysis is complete well before the prototype is built. Manufacturing lines are well equipped & flexible. With the aid of a highly responsive Supply Chain team, lead times are significantly crashed while ensuring high quality & reliability.

Rotomotive offers motors for various applications in industries like wind energy, hydraulic power packs, electric transportation, construction, mining, HVAC blowers, cooling units and smoke evacuation system.

Low Voltage Motors

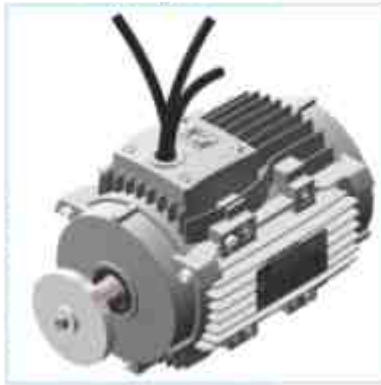

Material Handling System Motor



Hybrid Vehicles Motor

Crane Duty Motors

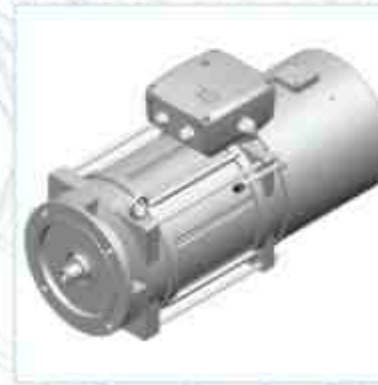

Tower Crane Hoist Motor



Overhead Crane Motor

HYDRAULIC PUMP MOTOR



Rotomotive has developed a whole range of hollow shaft motors, particularly for hydraulic pump application. This approach has significantly reduced the cost while at the same time improved efficiency. Final product is lighter & has reduced overall length.

Salient Features :

- Eliminate the need for shaft coupling.
- Compact design
- Low moment of inertia.
- High efficiency
- Plug & Play
- Option of high pressure oil seals.

SMOKE & HEAT EXHAUST VENTILATION MOTOR

Delfire series of motors are designed to be a part of smoke and heat control ventilation systems. These systems create a smoke free layer above the floor by removing the smoke. Thus, they improve conditions for safe escape/rescue of people, animals and the protection of property. They also permit the fighting of fire while still in its early stage.

They are also used with jet fans to convey smoke, NOx, carbon monoxide and other gases from tunnels, car parks, basement areas and the likes. In many cases they operate in the hazard prevention mode. In case of fire outbreak, the temperature rises rapidly. Delfire motor work for a guaranteed period of 1 or 2 hours at a continuous temperature of 300, 250 & 200° Celsius, depending upon requirement. These can be single or two speed motors and are governed by the harmonized European standard EN12101.



DIMENSIONS CHART



TYPE	POLES	AC	AD	H	KK	L	L1	D	DH	E	ED	F	G	GA	B3							B5, B3/B5							B14						
															A	AB	B	BB	C	HA	K	K1	M	N	P	R	S	T	LA	M	N	P	R	S	T
56	2-8	115	108	56	M16	198	223	9	M4x12	20	16	3	7.2	10.2	90	111	71	90	36	8	6	5.8	100	80	120	0	7	3	8	65	50	80	0	M5	2,5
63	2-8	122	109	63	M20	220	240	11	M4x12	23	16	4	8.5	12.5	100	124	80	105	40	8	9.5	7	115	95	140	0	10	3	10	75	60	90	0	M5	2,5
71	2-8	139	119	71	M20	244	281	14	M5X12	30	25	5	11.0	16.0	112	138	90	115	45	9	11	7	130	110	160	0	10	3.5	10	85	70	105	0	M6	2,5
80	2-8	157	131	80	M20	292	322	19	M6X16	40	30	6	15.5	21.5	125	157	100	130	50	9	14	10	165	130	200	0	12	3.5	12	100	80	120	0	M6	3,0
90S	2-8	176	145	90	M20	309	367	24	M8X19	50	40	8	20.0	27.0	140	173	100	130	56	11	14	10	165	130	200	0	12	3.5	12	115	95	140	0	M8	3,0
90L	2-8	176	145	90	M20	334	392	24	M8X19	50	40	8	20.0	27.0	140	173	125	155	56	11	14	10	165	130	200	0	12	3.5	12	115	95	140	0	M8	3,0
100L	2-8	197	159	100	M20	375	439	28	M10X22	60	50	8	24.0	31.0	160	196	140	180	63	12	16	12	215	180	250	0	15	4	13	130	110	160	0	M8	3,5
112M	2-8	221	177	112	M25	388	454	28	M10X22	60	50	8	24.0	31.0	190	227	140	185	70	12	16	12	215	180	250	0	15	4	14	130	110	160	0	M8	3,5
132S	2-8	260	197	132	M32	460	547	38	M12X28	80	65	10	33.0	41.0	216	260	140	185	89	15	16	12	265	230	300	0	15	4	14	165	130	200	0	M10	3,5
132M	2-8	260	197	132	M32	498	585	38	M12X28	80	65	10	33.0	41.0	216	260	178	225	89	15	16	12	265	230	300	0	15	4	14	165	130	200	0	M10	3,5
160M	2-8	315	255	160	2xM40	620	725	42	M16X36	110	90	12	37.0	45.0	254	320	210	260	108	20	15	15	300	250	350	0	19	5	14						
160L	2-8	315	255	160	2xM40	665	770	42	M16X36	110	90	12	37.0	45.0	254	320	254	305	108	20	15	15	300	250	350	0	19	5	14						
180M	2-8	380	280	180	2xM40	700	-	48	M16X36	110	90	14	42.5	51.5	279	355	241	300	121	24	15	15	300	250	350	0	19	5	15						
180L	2-8	380	280	180	2xM40	740	-	48	M16X36	110	90	14	42.5	51.5	279	355	279	350	121	24	15	15	300	250	350	0	19	5	15						
200L	2-8	420	305	200	2xM50	770	-	55	M20X42	110	90	16	49.0	59.0	318	395	305	370	133	24	19	19	350	300	400	0	19	5	16						
225S	4-8	470	335	225	2xM50	815	-	60	M20X42	140	110	18	53.0	64.0	356	435	286	375	149	28	19	19	400	350	450	0	19	5	22						
225M	2	470	335	225	2xM50	820	-	55	M20X42	110	90	16	49.0	59.0	356	435	311	390	149	28	19	19	400	350	450	0	19	5	22						
225M	4-8	470	335	225	2xM50	850	-	60	M20X42	140	110	18	53.0	64.0	356	435	311	390	149	28	19	19	400	350	450	0	19	5	22						
250M	2	510	370	250	2xM63	921	-	60	M20X42	140	110	18	53.0	64.0	406	490	349	440	168	32	24	24	500	450	550	0	19	5	25						
250M	4-8	510	370	250	2xM63	921	-	65	M20X42	140	110	18	58.0	69.0	406	490	349	440	168	32	24	24	500	450	550	0	19	5	25						
280S	2	580	410	280	2xM63	985	-	65	M20X42	140	110	18	58.0	69.0	457	550	368	460	190	36	24	24	500	450	550	0	19	5	28						
280S	4-8	580	410	280	2xM63	985	-	75	M20X42	140	110	20	67.5	79.5	457	550	368	460	190	36	24	24	500	450	550	0	19	5	28						
280M	2	580	410	280	2xM63	1035	-	65	M20X42	140	110	18	58.0	69.0	457	550	419	510	190	36	24	24	500	450	550	0	19	5	28						
280M	4-8	580	410	280	2xM63	1035	-	75	M20X42	140	110	20	67.5	79.5	457	550	419	510	190	36	24	24	500	450	550	0	19	5	28						
315S	2	615	530	315	2xM63	1160	-	65	M20X42	140	110	18	58.0	69.0	508	635	406	500	216	42	28	28	600	550	660	0	24	6	30						
315S	4-8	615	530	315	2xM63	1270	-	80	M20X42	170	140	22	71.0	85.0	508	635	406	500	216	42	28	28	600	550	660	0	24	6	30						
315M	2	615	530	315	2xM63	1190	-	65	M20X42	140	110	18	58.0	69.0	508	635	457	550	216	42	28	28	600	550	660	0	24	6	30						
315M	4-8	615	530	315	2xM63	1350	-	80	M20X42	170	140	22	71.0	85.0	508	635	457	550	216	42	28	28	600	550	660	0	24	6	30						
315L	2	615	530	315	2xM63	1190	-	65	M20X42	140	110	18	58.0	69.0	508	635	508	600	216	42	28	28	600	550	660	0	24	6	30						
315L	4-8	615	530	315	2xM63	1350	-	80	M20X42	170	140	22	71.0	85.0	508	635	508	600	216	42	28	28	600	550	660	0	24	6	30						
355M	2	710	655	355	2xM63	1500	-	75	M20X42	140	110	20	67.5	79.5	610	730	560	590	254	45	28	28	740	680	800	0	24	6	32						
355M	4-8	710	655	355	2xM63	1530	-	95	M20X42	170	140	25	86.0	100	610	730	560	590	254	45	28	28	740	680	800	0	24	6	32						
355L	2	710	655	355	2xM63	1500	-	75	M20X42	140	110	20	67.5	79.5	610	730	630	720	254	45	28	28	740	680	800	0	24	6	32						
355L	4-8	710	655	355	2xM63	1530	-	95	M20X42	170	140	25	86.0	100	610	730	630	720	254	45	28	28	740	680	800	0	24	6	32						

B3

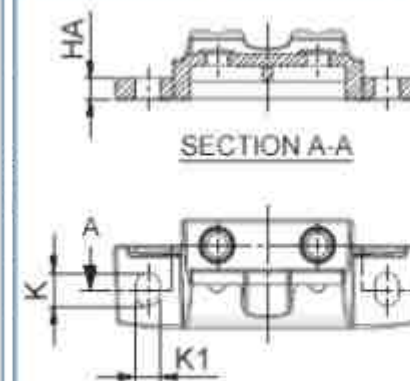
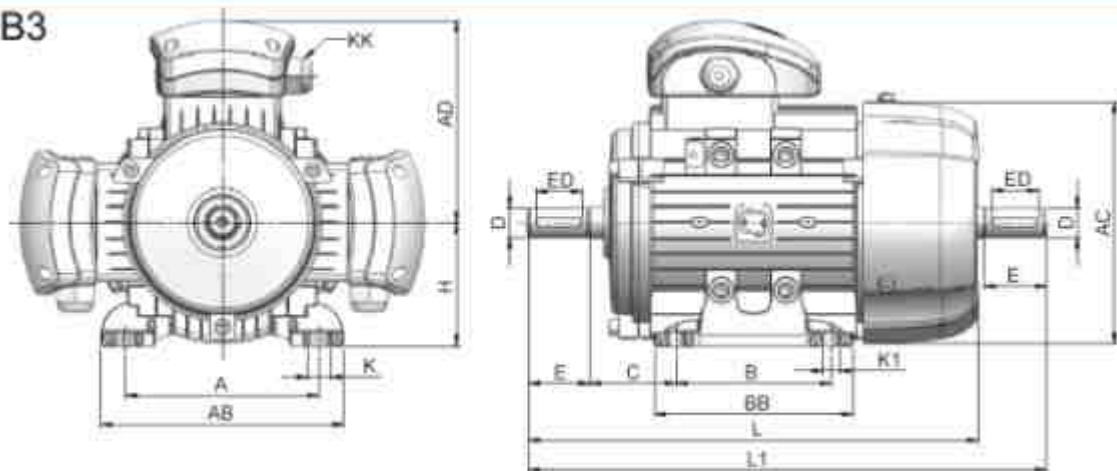

DETAILS OF FOOT

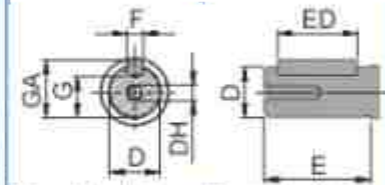

DE / NDE SIDE EXTENSION

B5 / B35

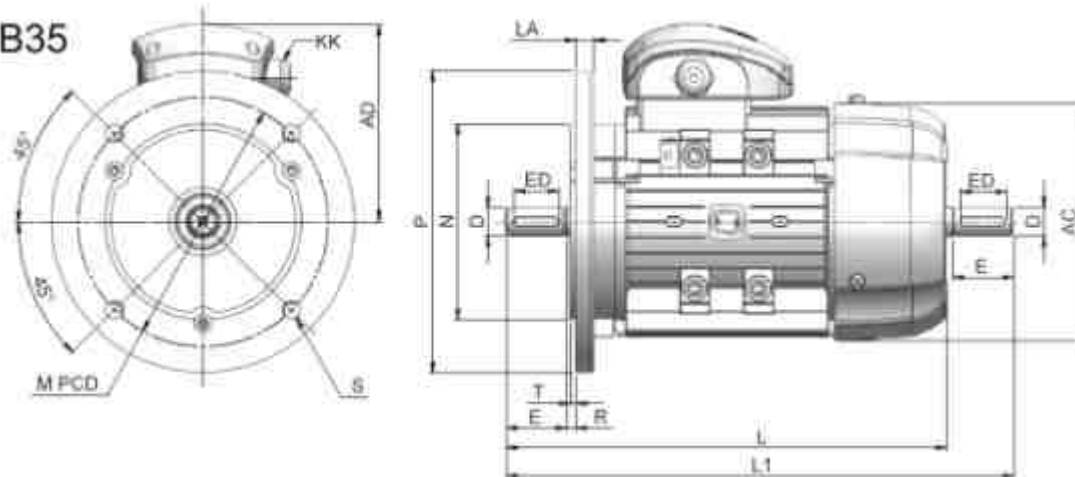

B14

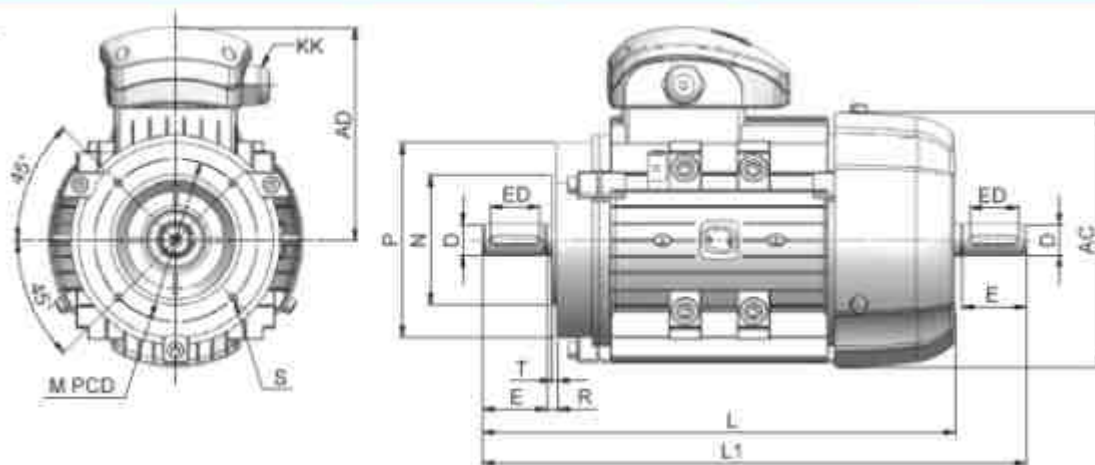

Rain Shield and Clean-flow fan cover:

For outdoor applications with V5-V18-V1-V15 installation position, we recommend the use of rain shield. This configuration may also be used in textiles processing industry having lot of fibers in the atmosphere which can clog the fan if not used with a clean flow fan cover.



TYPE	L
63	215
71	323
80	369
90S	403
90L	428
100	469
112	453
132S	573
132M	613
160M	770
160L	825
180M	915
180L	955
200L	1025
225S	1155
225M	1160
250M	1220
280S	1265
280M	1315
315S	1540
315M	1570
315L	1680
355M	1840
355L	1870

DELPHI ATDC / AT24

Delphi AT..... series self-braking motors use spring pressure brakes, firmly spliced on to a cast iron shield fixed on to the non-driving end of the motor.

These motors include following features as standard unlike other brands which consider these features as optional:

The hand release lever : permits the release the brake, making it possible to rotate the shaft.

The brake can be energized by connecting the supply to its terminals which are located inside the motor terminal box.

3 PTCS, one per phase, duly connected in series, This is a standard feature from frame size 160 and onwards.

Rotomotive also offer PTO thermal protection on request. To enable automatic switching of power cooling fan the PTO can have as NO contact.

Delphi ATDC series motors use DC brakes power supplied by a rectifier installed inside the motor main terminal box. Unless there is a different request of the client, Rotomotive supplies ATDC rake motors with the rectifier already connected to the main terminal block of the motor, in order to permit to the motor switching to act as the same time on the brake.

In case that the motor is power supplied by a frequency inverter, or in case that the motor is used to move loads which can have an inertial movement, like lifted weights (such inertial movement can move the motor when the power is switched off, and the motor can act like a generator on the rectifier avoiding brake locking), disconnect the motor main terminal board from the rectifier, and connect separately the rectifier [ATDC].

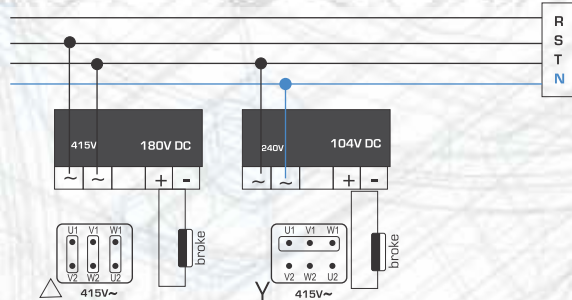

Delphi AT24 series motors use DC electromagnetic brakes with 24V DC input type which can be operated through an inverter (usually having 24Vdc port.)

Brake coil insulation class H & brake lining is asbestos-free.

The rectifier is MOSFET type, with protection varistors at the entry and exit. All brake assemblies are protected against corrosion by painting or hot galvanizing and resin impregnated winding. The parts most subject to wear are treated in special atmospheres that provided considerable wear resistance to the parts.

The performance of all brakes, in terms of Watt, Nm and time in Sec are shown in table given below

EC Type	ATDC					AT24				ATDC AT24
	Static max braking torque [Nm]	Braking time no-load [Sec]	Input voltage on rectifier [Vac]	Output voltage to brake [Vdc]	Brake power W	Static max braking torque [Nm]	Static min braking torque [Nm]	Braking time no-load [Sec]	Brake power W	extra Kg on Std
AT..63	4,5	0,15	240	104	22	7,0	4,5	0,06	20	+4
AT..71	8,0	0,15	240	104	28	7,0	4,5	0,06	20	+5
AT..80	12,5	0,20	240	104	30	14,0	9,5	0,09	25	+5,5
AT..90	25,0	0,25	240	104	45	24,0	12,0	0,11	30	+6
AT..100	38,0	0,30	240	104	60	60,0	28,0	0,14	45	+7
AT..112	70,0	0,35	415	180	65	80,0	60,0	0,15	65	+10
AT..132	140,0	0,40	415	180	88	120,0	110,0	0,16	85	+12
AT..160	210,0	0,50	415	180	110	160,0	130,0	0,21	105	+22

DELPHI ATAC

Delphi ATAC series self-braking motors use brake similar in working with DC electromagnetic type but operated on AC power supply. As these brakes are operated on AC supply, no need of rectifier.

The torque value offered for ATAC series motors are as under.

Type	Static Braking Torque Nm	Input Power W	Input Voltage to brake Vac	extra Kg on std.
ATAC63	4,5	40	415	4,2
ATAC71	8	70	415	5,2
ATAC80	12	85	415	5,8
ATAC90	16	120	415	6,3
ATAC100	45	160	415	7,4
ATAC112	70	300	415	10,6
ATAC132	140	500	415	13

Dimensions ATDC / AT24 / ATAC

	ATDC/AT24		ATAC	
	L	L2	L	L2
63	275	120	300	105
71	300	130	334	115
80	340	140	360	140
90S	385	140	387	163
90L	410	140	412	163
100L	445	165	474	194
112M	472	174	494	203
132S	550	214	577	230
132M	590	214	615	230
160M	715	220	-	-
160L	760	220	-	-

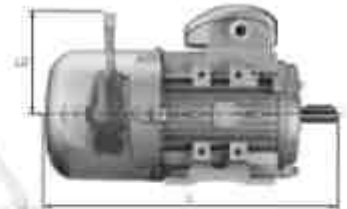

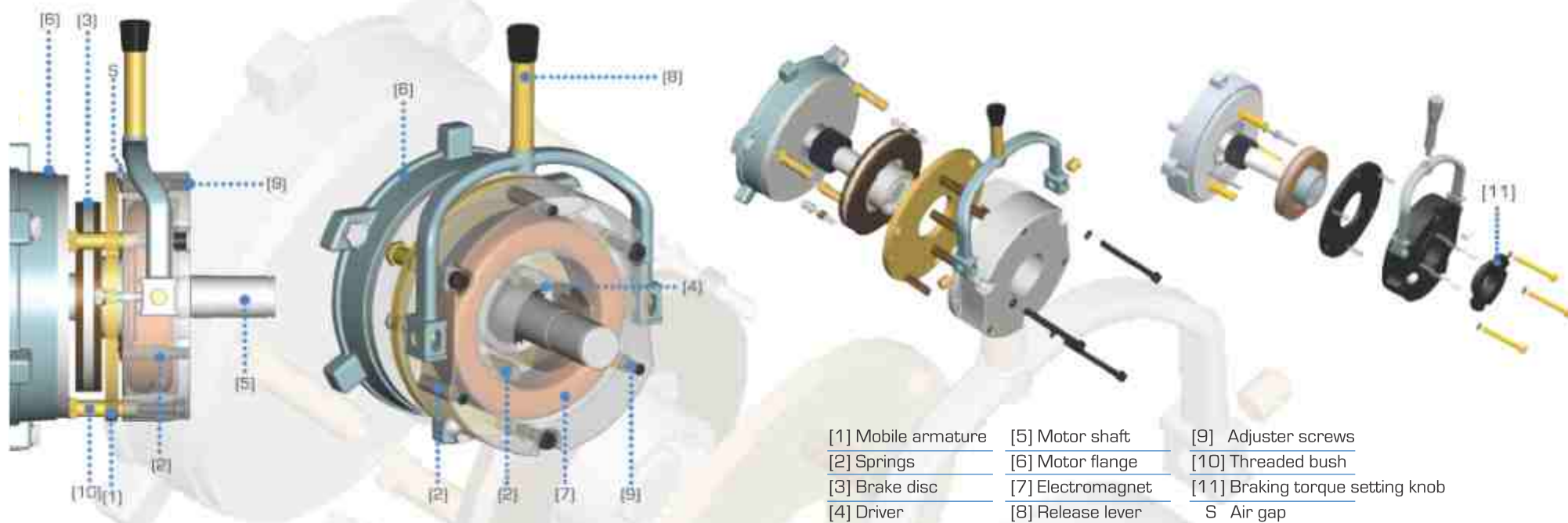

- [1] Mobile armature
- [2] Springs
- [3] Brake disc
- [4] Driver
- [5] Motor shaft
- [6] Motor flange
- [7] Electromagnet
- [8] Release lever
- [9] Adjuster screws
- [10] Threaded bush
- [11] Braking torque setting knob
- S Air gap

BRAKE DESCRIPTION

ADJUSTMENT

SWITCHING (ATDC)

The brakes used in Delphi ATDC, AT24 and ATAC series are of electromagnetic type and normally OFF i.e. the braking action occurs in the absence of power supply. The brake insulation class is F. The brake lining is asbestos free as per most recent EEC Directives pertaining to Workplace Hygiene and Safety. All brake assemblies are protected against corrosion by painting or heat galvanizing and resined winding. The parts most subjected to wear are specially treated to ensure they become wear resistance.

Two different types of adjustment are possible.
S air gap adjustment
 For proper operation the air gap S between electromagnet (7) and the mobile armature (1) must be between the following indicated limits.

MOTOR TYPE (ATDC/AT24)	S AIR GAP (mm)	MOTOR TYPE (ATAC)	S AIR GAP (mm)
63 -71	0.40-0.50	63 -90	0.2
80 -160	0.50-0.60	100-132	0.3

Two type of switching possible for brake coils operated with DC voltage, one is AC side switching and another is DC side switching.
 Generally when braking time is not critical AC side switching is done. AC side switching is often used with brake motors, where brake is connected with motor's main terminal block. Due to the inductance of the brake coil, engagement time can be 3 to 6 times longer than with DC switching. Therefore this arrangement is not suitable for hoist applications.

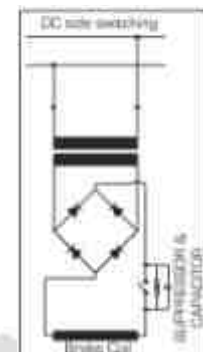
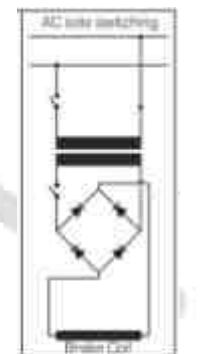

BRAKE OPERATION

The adjustment is made by using the threaded bushes (10) and using a thickness gauge to ensure that the required air gap is maintained.

Braking Torque Adjustment
 The braking torque is set to its maximum value by Rotomotive. But it can be decreased by acting on the adjuster screws (9) [ATDC/ ATAC motor] or on the knob (11) [AT24 motor]

DC side switching is necessary when there is motor subjected to inertial movement, like lifted weights such as hoist, lifts and cranes, a brake motor regenerate the supply upto some extent and hold off the brake. DC side switching requires provision of universal spark suppressor and capacitor to protect the coil and switches against inductive voltage.

Rotomotive supply rectifier of Mosfet type, with protection varistors at the entry and the exit.

Delphi CR series motors are compact asynchronous squirrel cage induction motors specially designed for use in cranes and hoists. They can also be used for other applications like material handling, weirs and sluices and lifts of all types. These motors can serve as auxiliary motors in rolling mills or wherever intermittent drives are required.



These motors are typically in one frame size lower than S1 duty motors and are of S3/S4/S5 duty, developing high starting torque with low starting current. The Motors are suitable for frequent starts/stops and reversals and conform to IS:325 for three phase induction motors and IS:4722 for rotating electrical Machines as well as IEC-34.1. These motors are available in frame sizes from 71 to 160 in 4 or 6 poles.

Enclosures, Cooling, Mounting and Supply conditions :

The enclosures, cooling, mounting and voltage supply conditions and tolerances are similar to Delphi Series EFF2 motors.

Types of Intermittent Duty Ratings :

The basis of these ratings is that of thermal capability, taking into account:

- i) Frequency of starting (starting class).
- ii) Percentage of time during each operating cycle the motor is energized, (CDF- Cyclic duration factor).
- iii) The number and type of operating cycles per hour, (duty class).
- iv) And the inertia of the motor and the load.

Motors with Integral Brakes:

These motors can be supplied with integral fail safe D.C. Brakes, with built in rectifiers. Brakes of 24 Volts for direct use with VFD drives are also available.

For braking torque values, refer to the section on Brake motors.

Definitions :

The terms used frequently in intermittent duty drive and hoisting are as bellow:

1. Cyclic duration factor : (CDF)

The ratio between the period of loading including starting and electric braking and the total duration of the duty-cycle expressed as a percentage.

2. Jogging or inching :

This is an incomplete start during which the motor does not attain more than 25% of the rated speed.

3. Electric braking :

A system in which a braking action is applied to an electric motor by causing it to act as a generator

4. D.C. Injection braking :

A form of braking of an induction motor in which a separate dc supply is used to magnetize the motor.

5. Plug braking :

A form of electric braking of an induction motor obtained by reversing the phase sequence of its any two lines.

6. Regenerative braking :

A system of electric braking in which energy is returned to the supply system.

Duty type :

Crane duty applications can be classified into duty types S3 to S5

Intermittent periodic duty

Duty type S3 :

A sequence of identical duty cycle, each including a period of operation at constant load and a rest and de-energized period. These periods being too short to attain thermal equilibrium during one duty cycle. In this duty type, the starting current does not significantly affect the temperature rise.

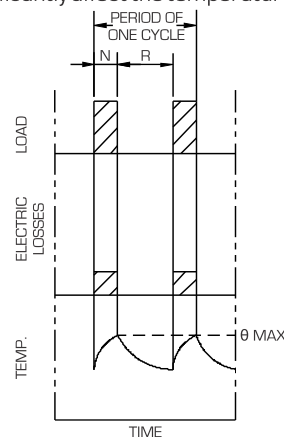

θ MAX. = MAX. TEMP. ATTAINED DURING DUTY CYCLE

N = OPERATION AT CONSTANT LOAD

R = AT REST & DE - ENERGISED

$$\text{CYCLIC DURATION FACTOR} = \frac{N}{N + R} \times 100\%$$

Intermittent periodic duty with starting
Duty type S4 :

A sequence of identical duty cycles, each cycle including a significant period of starting. A period of operation at constant load and a rest de-energized period. These period being too short to attain thermal equilibrium during one duty cycle.

In this duty, the stopping of the motor is obtained either by natural de-acceleration after disconnection of the supply or by means of braking such as a mechanical brake which does not cause additional heating of the windings.

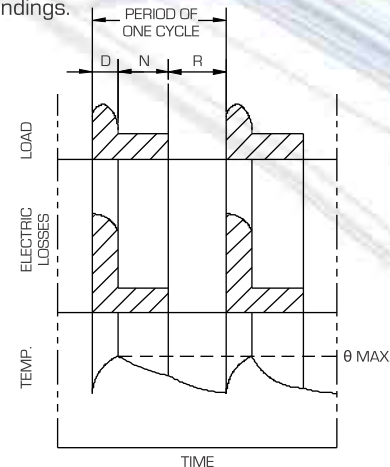

θ MAX. = MAX. TEMP. ATTAINED DURING DUTY CYCLE

N = OPERATION AT CONSTANT LOAD

R = AT REST & DE - ENERGISED

D = STARTING TIME

$$\text{CYCLIC DURATION FACTOR} = \frac{D+N}{D+N+R} \times 100\%$$

Intermittent periodic duty with starting and braking
Duty type : S5

A sequence of identical duty cycles, each cycle consisting of a period of starting, a period of operation at constant load, a period of rapid electric braking and rest and de-energized period. The operating and rest and de-energized periods being too short, to attain thermal equilibrium during one duty cycle.

Note : In all above type of duties, the loading period and rest period of the cycle are so short that the steady state temperature is not reached. While working on these identical cycles continuously, the motor temperature rise must not exceed the permissible values for a given class of insulation.

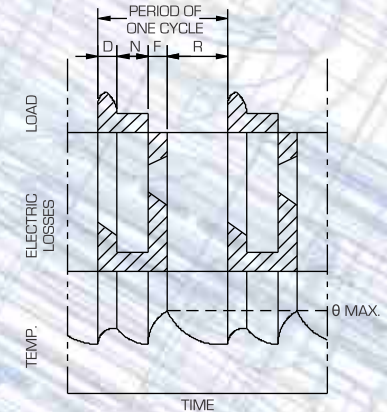

θ MAX. = MAX. TEMP. ATTAINED DURING DUTY CYCLE

N = OPERATING AT CONSTANT LOAD

R = AT REST & DE - ENERGISED

D = STARTING TIME

F = ELECTRIC BRAKING

$$\text{CYCLIC DURATION FACTOR} = \frac{D+N+F}{D+N+F+R} \times 100\%$$

The common cyclic duration factors (CDF) for the duties S3, S4 and S5 are 25%, 40%, and 60%. Motors with CDFs other than these values can also be supplied on request.

How to select motors for hoisting and similar duties.

The formula to establish the rated Pn in Kw

$$P_n > \frac{FXV}{102 X \text{Eff}} \text{ Kw}$$

Where F = Maximum load in Kg.

V = Hoisting speed in mtr/sec

Eff. = Overall mechanical efficiency of the driving unit.

For Horizontal motion ensure that the rated output Pn of the motor is greater than the power necessary to move the equipment given by:

$$P_n > \frac{M \times n}{974 \times \text{Eff}} \text{ Kw}$$

Where M = Torque reqd. for movement in Kg.m

n = Motor RPM



PERFORMANCE CHART

4 Pole asynchronous speed 1500 rpm						S3 Duty				S4 & S5 Duty							
						60 Starts				150 Starts				300 Starts			
Type	Rated RPM	Current [ls/ln]	Torque Cn(Nm)	Torque Cs/Cn	Torque Cmax/Cn	25% OR 40% CDF		60% CDF		25% OR 40% CDF		60% CDF		25% OR 40% CDF		60% CDF	
						Rated		Rated		Rated		Rated		Rated		Rated	
						KW	Amp	KW	Amp	KW	Amp	KW	Amp	KW	Amp	KW	Amp
71	1315	3.7	4.00	2.3	2.8	0.55	1.55	0.55	1.55	0.55	1.55	0.55	1.55	0.55	1.55	0.55	1.55
80	1385	4.5	5.20	2.3	2.8	0.75	1.9	0.75	1.9	0.75	1.9	0.75	1.9	0.75	1.9	0.75	1.9
80	1385	4.5	7.60	2.8	3.0	1.1	2.8	1.1	2.8	1.1	2.8	1.1	2.8	1.1	2.8	1.1	2.8
90S	1400	4.7	10.20	2.3	2.8	1.5	3.7	1.5	3.7	1.5	3.7	1.5	3.7	1.5	3.7	1.5	3.7
90L	1380	5.2	15.30	2.7	3.2	2.2	4.95	2.2	4.95	2.2	4.95	2.2	4.95	2.2	4.95	2.2	4.95
100L	1380	6.0	25.60	2.7	3.2	3.7	8.0	3.7	8.0	3.7	8.0	3.7	8.0	3.7	8.0	3.7	8.0
112M	1425	6.0	36.90	2.6	3.0	5.5	11.6	5.5	11.6	5.5	11.6	5.5	11.6	5.5	11.6	5.5	11.6
132S	1410	6.0	50.80	2.5	3.0	7.5	15.5	7.5	15.5	7.5	15.5	7.5	15.5	7.5	15.5	7.5	15.5
132M	1440	6.5	61.60	2.7	3.0	9.3	18.0	9.3	18.0	9.3	18.0	9.3	18.0	9.3	18.0	9.3	18.0
160M	1450	6.0	72.44	2.25	2.7	11	22.0	11	22.0	11	22.0	11	22.0	11	22.0	11	22.0
160M	1430	6.0	100.17	2.3	2.7	15	30.5	15	30.5	15	30.5	15	30.5	15	30.5	15	30.5
160L	1440	6.5	122.68	2.5	3.0	18.5	36.0	18.5	36.0	18.5	36.0	18.5	36.0	18.5	36.0	18.5	36.0

6 Pole asynchronous speed 1000 rpm						S3 Duty				S4 & S5 Duty							
						60 Starts				150 Starts				300 Starts			
Type	Rated RPM	Current [ls/ln]	Torque Cn(Nm)	Torque Cs/Cn	Torque Cmax/Cn	25% OR 40% CDF		60% CDF		25% OR 40% CDF		60% CDF		25% OR 40% CDF		60% CDF	
						Rated		Rated		Rated		Rated		Rated		Rated	
						KW	Amp	KW	Amp	KW	Amp	KW	Amp	KW	Amp	KW	Amp
71	870	3.0	4.00	2.3	2.6	0.37	1.4	0.37	1.4	0.37	1.4	0.37	1.4	0.37	1.4	0.37	1.4
80	900	4.0	5.84	2.3	2.6	0.55	1.55	0.55	1.55	0.55	1.55	0.55	1.55	0.55	1.55	0.55	1.55
80	885	4.0	8.10	2.3	2.6	0.75	2.4	0.75	2.4	0.75	2.4	0.75	2.4	0.75	2.4	0.75	2.4
90S	910	4.0	11.55	2.3	2.6	1.1	2.9	1.1	2.9	1.1	2.9	1.1	2.9	1.1	2.9	1.1	2.9
90L	895	4.5	16.00	2.3	2.8	1.5	4.2	1.5	4.2	1.5	4.2	1.5	4.2	1.5	4.2	1.5	4.2
100L	925	4.5	22.70	2.3	2.8	2.2	6.4	2.2	6.4	2.2	6.4	2.2	6.4	2.2	6.4	2.2	6.4
112M	925	4.6	38.20	2.3	2.8	3.7	8.9	3.7	8.9	3.7	8.9	3.7	8.9	3.7	8.9	3.7	8.9
132S	930	6.0	56.50	2.3	2.8	5.5	14.2	5.5	14.2	5.5	14.2	5.5	14.2	5.5	14.2	5.5	14.2
132M	930	6.0	77.00	2.3	2.8	7.5	18.0	7.5	18.0	7.5	18.0	7.5	18.0	7.5	18.0	7.5	18.0
160M	950	6.0	93.48	2.3	2.7	9.3	20.0	9.3	20.0	9.3	20.0	9.3	20.0	9.3	20.0	9.3	20.0
160L	960	6.0	109.42	2.3	2.7	11	24.0	11	24.0	11	24.0	11	24.0	11	24.0	11	24.0
160L	950	6.5	150.78	2.3	2.6	15	33.0	15	33.0	15	33.0	15	33.0	15	33.0	15	33.0

● All performance are declared at rated voltage 415 & Frequency 50Hz and are subjected to tolerances as per IS:325. For dimensions refer chart on page no: 20 - 21

EFF 2

IE 2

IE 3

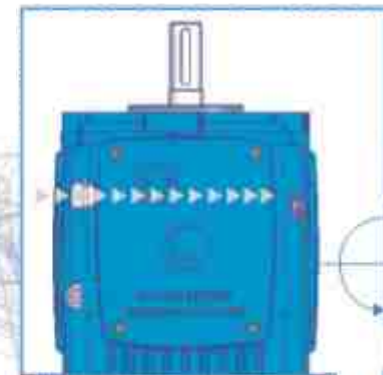
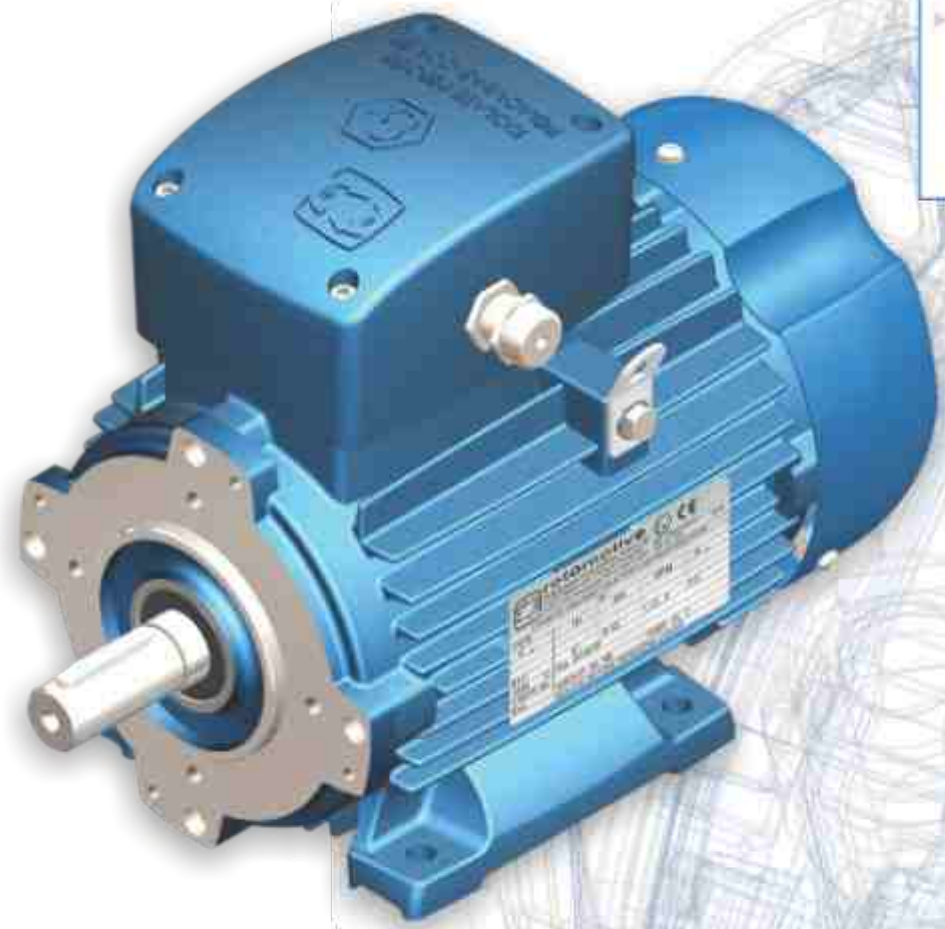
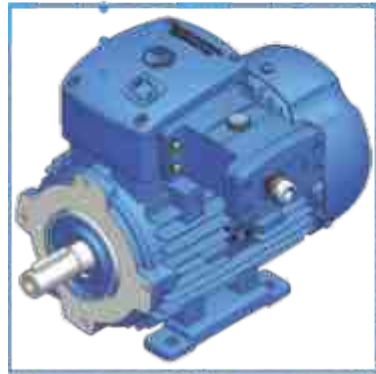

The terminal box can be rotated at every 180° steps.

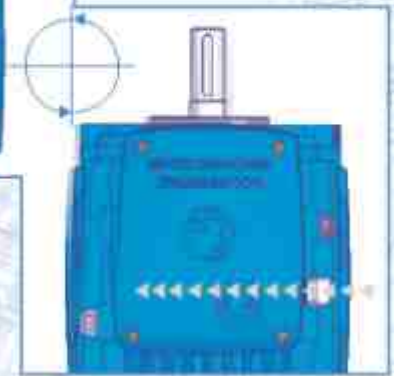

Epoxy paint



Upto 132 frame convertibility from B3 construction to B35 or B34 without dismantling the drive end cover.

The use of electrical motors in potentially explosive atmospheres is quite frequent these days. These motors must be constructed in a manner to contain the spark within the enclosure in event of any explosion within the body/enclosure of the motor. An Explosion occurs when the following situations occur:

- Presence of potentially explosive atmosphere
- Existence of a source of ignition
- Possibility of transmission of the explosion

Delphi Exd series asynchronous 3 Phase squirrel cage induction motors are manufactured as per IS/IEC 60079-1:2007 for operation in hazardous locations classified as zone 1 and zone 2 areas as per IS:5572. These motors are available in frame sizes of 80 to 160 in 2, 4, 6 and 8 pole ratings. For specifications and performance parameters, refer to tables on page 10-13. The motor enclosure has been designed in a way to prevent the transmission of internal explosion to the explosive atmosphere surrounding the machine. The enclosure is designed to withstand, without damage, any pressure levels caused by an internal explosion. Care has been taken to ensure the shape, length and gap of assembly joints, at shaft opening, cable entries, etc are suitable for throttling and cooling of hot gases before they escape outside.

Classification of Hazardous Environment : According to IS: 5572, Hazardous area are classified in the following ways depending on the probability of the presence of hazardous atmosphere.

Zone : Criteria presence of gas
 Zone 1 Present in normal operations
 Zone 2 Unlikely, but if present, only for a short time

Application Groups : Depending on the intended use, explosion-proof electrical operating equipment is divided into two major groups:

- Group I Equipment for coal mines (Only specially designed motors for mines can be use)
- Group II Electrical equipment for use other than mines (surface industry)

Group II Motors with flameproof enclosures are further divided into gas groups :
 II A Propane
 II B Ethylene

Temperature Classes : Combustible gas of Vapour and explosion-protected electrical equipments are divided into temperature of the gas T4 to T6 with regard to the ignition temperature of the gas or vapour and the maximum surface temperature of the component. Delphi Exd series motors are suitable for Temperature class T4, T5 and T6.

Temperature class	Maximum permitted surface Temperature of electrical equipment °C
T4	135
T5	100
T6	85

Zone 2
Abnormal Conditions
 Presence of explosive atmosphere only by accident, but not during normal duty (< 10 H per year)

Zone 1
 Occasionally
 Incidental Presence of explosive atmosphere during normal duty (10-1000 H per year)

Description of the marking on motor Nameplate :

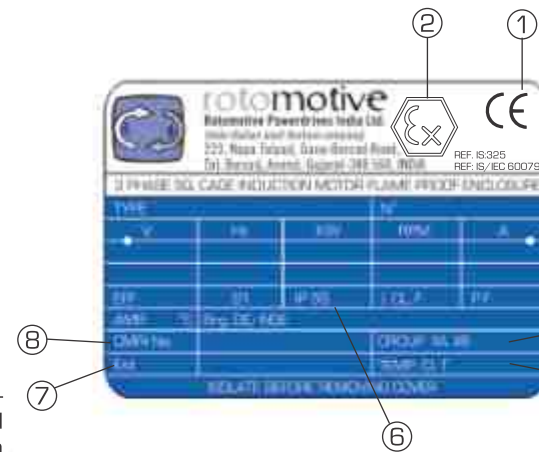

1. Marking of conformity in compliance with the European Directives.
2. Specific marking of explosion protection.
3. Motor Serial No.
4. Group [surface plants different from mines]
5. Temperature class of the motor (GAS).
6. IP protection degree.
7. Type of protection for explosive atmosphere for the presence of flammable gas.
8. Type Certificate Number.

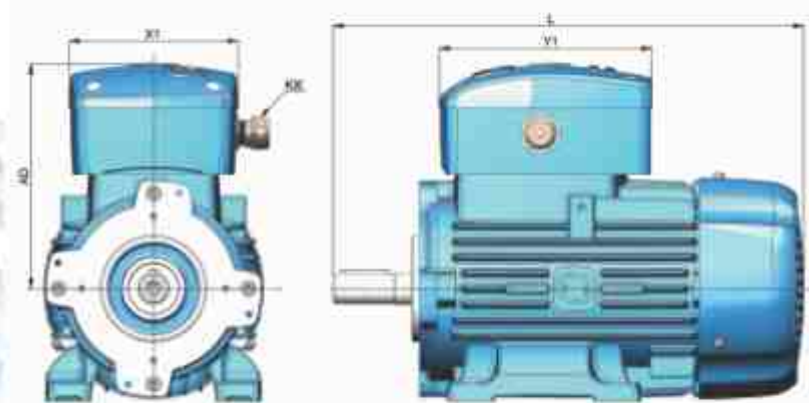

FRAME	L	AD	X1	Y1	KK
Ex80	315	160	100	138	M20
Ex90	380	180	133	170	M20
Ex100	410	195	133	170	M20
Ex112	430	216	158	190	M25
Ex132M	495	236	158	190	M32
Ex160M	605	310	185	208	M40
Ex160L	650	310	185	208	M40

COMPONENTS LIST

types 180-355

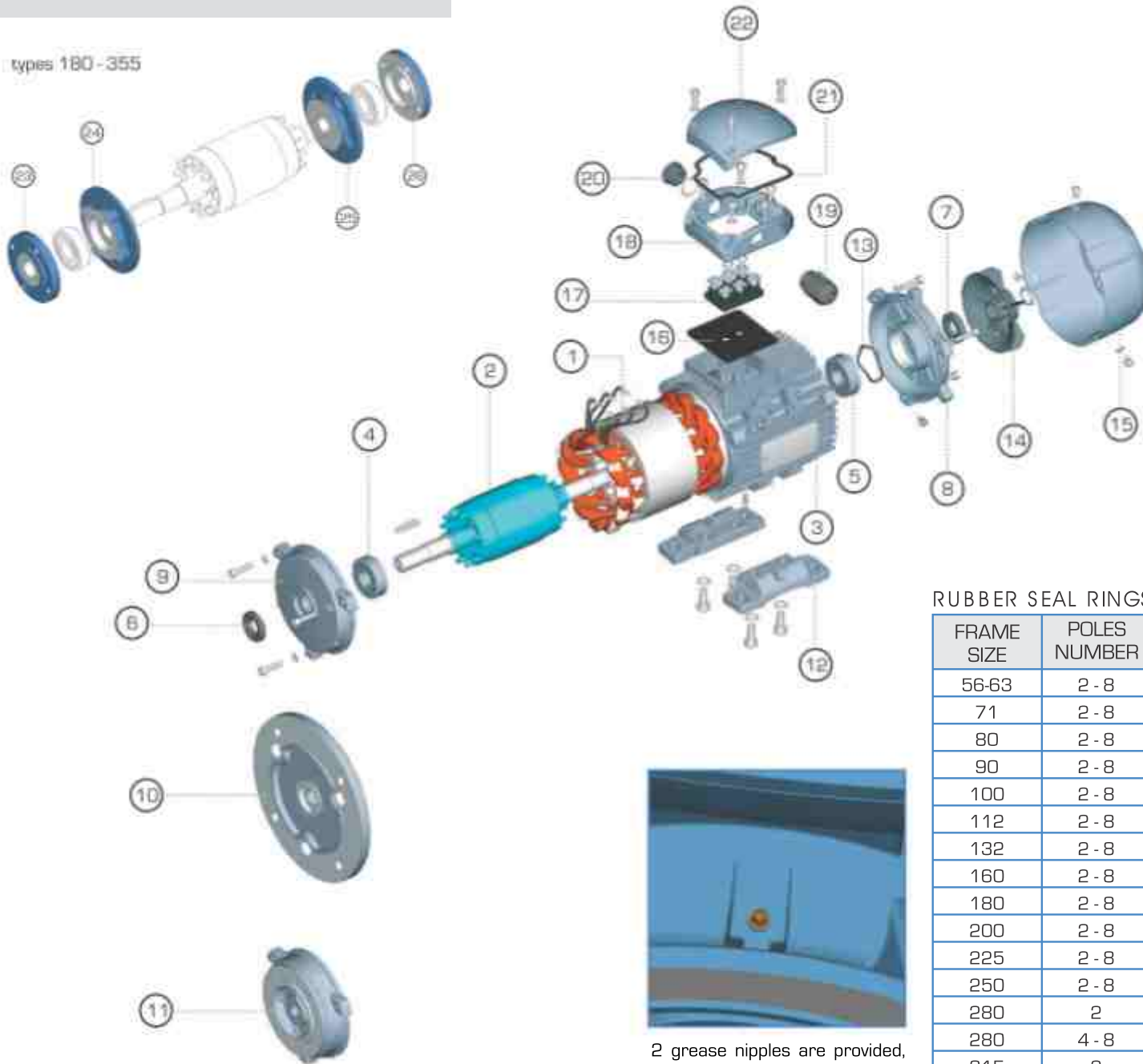

Sr. No.	Description
1	Wound stator with motor body
2	Diecast rotor with shaft
3	Name plate
4	Bearing (DE side)
5	Bearing (NDE side)
6	Oil seal
7	V seal
8	NDE cover
9	DE cover
10	B5 flange
11	B14 flange
12	Foot
13	Wave washer
14	Fan
15	Fan cover (cowl)
16	Rubber gasket
17	Terminal block
18	Terminal box
19	Cable gland
20	Plug
21	O ring
22	Terminal box cover
23	Outside bearing cover (DE side)
24	Inside bearing cover (DE side)
25	Inside bearing cover (NDE side)
26	Outside bearing cover (NDE side)

RUBBER SEAL RINGS AND BEARINGS

FRAME SIZE	POLES NUMBER	RUBBER SEAL RING		BEARINGS	
		6	7	4	5
56-63	2 - 8	12X25X7	12X25X7	6201 ZZ	6201 ZZ
71	2 - 8	15X30X7	15X30X7	6202 ZZ	6202 ZZ
80	2 - 8	20X35X7	20X35X7	6204 ZZ	6204 ZZ
90	2 - 8	25X40X7	25X40X7	6205 ZZ	6205 ZZ
100	2 - 8	30X47X7	30X47X7	6206 ZZ	6206 ZZ
112	2 - 8	30X47X7	30X47X7	6206 ZZ	6206 ZZ
132	2 - 8	40X62X7	40X62X7	6208 ZZ	6208 ZZ
160	2 - 8	45X62X8	45X62X8	6309 ZZ	6309 ZZ
180	2 - 8	55X72X8	55X72X8	6311-C3	6311-C3
200	2 - 8	60X80X8	60X80X8	6312-C3	6312-C3
225	2 - 8	65X80X10	65X80X10	6313-C3	6313-C3
250	2 - 8	70X90X10	70X90X10	6314-C3	6314-C3
280	2	70X90X10	70X90X10	6314-C3	6314-C3
280	4 - 8	85X100X12	85X100X12	6317-C3	6317-C3
315	2	85X110X12	85X110X12	6317-C3	6317-C3
315	4 - 8	95X120X12	95X120X12	NU319-C3	6319-C3
355	2	95X120X12	95X120X12	6319-C3	6319-C3
355	4 - 8	110X130X12	110X130X12	NU322-C3	6322-C3

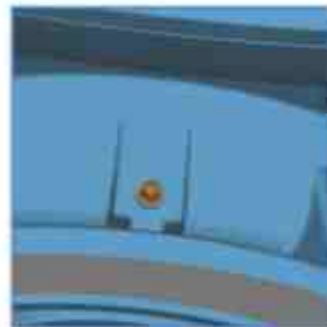

2 grease nipples are provided, one on each end-cover from frame size 180 and up. Other motors till frame size 160 have shielded bearings, pre-lubricated for life.

We recommend the use of SKF shielded bearings with LHT23 grease suitable for -40°C to +140°C.